

LMS58 HR25



Printed Matter No. 9836 6498 00

Impact Wrench

Valid from Serial No. B5440001
2014-11

Product Instructions



	 WARNING



General information

⚠ WARNING

- Read all safety warnings and all instructions.
Failure to follow the warnings and instructions may result in electric shock, fire and/or serious injury.
- Save all warnings and instructions for future reference.

Safety signal words

The safety signal words Danger, Warning, Caution, and Notice have the following meanings:

DANGER	DANGER indicates a hazardous situation which, if not avoided, will result in death or serious injury.
WARNING	WARNING indicates a hazardous situation which, if not avoided, could result in death or serious injury.
CAUTION	CAUTION, used with the safety alert symbol, indicates a hazardous situation which, if not avoided, could result in minor or moderate injury.
NOTICE	NOTICE is used to address practices not related to personal injury.

Warranty

Contact the Atlas Copco sales representative within your area to claim a product. Warranty will only be approved if the product has been installed, operated and overhauled according to the Operating Instructions.

Please also see the delivery conditions applied by the local Atlas Copco company.

ServAid

ServAid is a utility for providing updated product information concerning:

- Safety instructions
- Installation, Operation and Service instructions
- Exploded views

ServAid facilitates the ordering process of spare parts, service tools and accessories for the product of your choice. It is continuously updated with information of new and redesigned products.

You can use ServAid to present content in a specific language, provided that translations are available, and to display information about obsolete products. ServAid offers an advanced search functionality of our entire product range.

ServAid is available on DVD and on the web:

<http://servaidweb.atlascopco.com>

For further information contact your Atlas Copco sales representative or e-mail us at:

servaid.support@se.atlascopco.com

Further information

For further information concerning this product, please see Printed Matter No. -, available in ServAid on the web.

Overview

Applications

This powerful, high-speed impact wrench (LMS) is typically used for loosening applications where fast tightening or disassembly is needed.

Service intervals

Service recommendations

Service must only be carried out by qualified personnel who have access to the Service Instruction and/or have been trained for service on QST Tools.

The electric motor is a sealed unit and may under no circumstances be opened by anyone else than Atlas Copco Industrial Technique AB! If it is judged that the electric motor is defect or in need of service, the complete motor unit should be returned to Atlas Copco for exchange. Motors which have been opened by anyone else than Atlas Copco will not be serviced.

Installation requirement

General

The machine is designed for a working pressure (e) of 6.3 - 7 bar (max.) = 630 - 700 kPa (90 - 102 psi).

If the compressed air line pressure is higher than 7 bar it is preferable reduced with a pressure regulator of the type Atlas Copco REG.

The Atlas Copco Air Line Test equipment is suitable for checking of air pressure and airflow at the installation point (please see AirLine Accessories in our main catalogue).

The machine can operate at a lower working pressure. Maximum torque will be reduced at lower pressures.

- ⓘ **If frequent used for tightening or loosening that need longer time than 3-5 seconds, a larger wrench should be used. Otherwise the servicelife of the impact mechanism will be reduced.**

To avoid pressure drop use recommended hosesize, length, and connections. For more information please read Atlas Copco Airline Installations, Ordering No. 9833 1191 01.

Air quality

- For optimum performance and maximum machine life we recommend the use of compressed air with a maximum dew point of +10°C. We also recommend the installation of an Atlas Copco refrigeration-type air dryer.
- Use a separate air filter of type Atlas Copco FIL. This filter removes solid particles larger than 15 microns and also removes more than 90 % of liquid water. The filter must be installed as close as possible to the machine/equipment and prior to any other air preparation unit such as REG or DIM (please see Air Line Accessories in our main catalogue). Blow out the hose before connecting.

Models which need air lubrication:

- The compressed air must contain a small quantity of oil.
We strongly recommend that you install an Atlas Copco oil-fog lubricator (DIM). This should be set according to air consumption by the air line tool according to the following formula:

L = Air consumption (litre/s).

(May be found in our sales literature).

D = Number of drops per min (1 drop = 15 mm³)

$L * 0.2 = D$

this applies to the use of long work cycle air line tools. A single point lubricator type Atlas Copco Dosol can also be used for tools with short running cycles.

Information about Dosol settings may be found under Air Line Accessories in our main catalogue.

Lubrication-free models:

- In the case of lubrication-free tools it is up to the customer to decide on the peripheral equipment to be used. However, it is no disadvantage if the compressed air contains a small quantity of oil e.g. supplied from a fog lubricator (DIM) or Dosol system. This does not apply to turbine tools, which should be kept oil free.

Installation proposal

Choosing the correct couplings, hose and clamps can be a troublesome digging into details. To save your time and to ensure correct capacity of the airline installation, from the tapping point to the tool, we offer you an installation proposal.

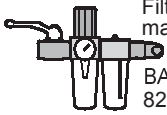

Filtered, regulated and oil fog lubricated air for a max. air flow of 22 l/s

BALL VALVE + MIDI F/RD 15 + ERGOQIC 10
8202 0829 11

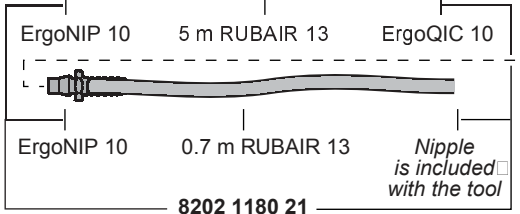

Ergonomics

Ergonomic guidelines

Consider your workstation as you read through this list of general ergonomic guidelines and see if you can identify areas for improvement in posture, component placement, or work environment.

- Take frequent breaks and change work positions frequently.
- Adapt the workstation area to your needs and the work task.
 - Adjust for convenient reach range by determining where parts or tools should be located to avoid static load.
 - Use workstation equipment such as tables and chairs appropriate for the work task.
- Avoid work positions above shoulder level or with static holding during assembly operations.
 - When working above shoulder level, reduce the load on the static muscles by reducing the weight of the tool, using for example torque arms, hose reels or weight balancers. You can also reduce the load on the static muscles by holding the tool close to the body.
 - Make sure to take frequent breaks.
 - Avoid extreme arm or wrist postures, particularly for operations requiring a degree of force.
- Adjust for convenient field of vision by minimizing movement of the eyes and head during the work task.
- Use the appropriate lighting for the work task.
- Select the appropriate tool for the work task.
- Use ear protection equipment in noisy environments.
- Use high-quality inserted tools or consumables to minimize exposure to excessive levels of vibrations.
- Minimize exposure to reaction forces.
 - When cutting:
A cut-off wheel can get stuck if the wheel is either bent or if it is not guided properly. Make sure to use correct flanges for cut-off wheels and avoid bending the wheel during cut-off operation.
 - When drilling:
The drill might stall when the drill bit breaks through. Make sure you use support handles if the stall torque is too high. The safety standard ISO11148 part 3 recommends to use something to absorb the reaction torque above 10 Nm for pistol grip tools and 4 Nm for straight tools.
 - When using direct driven screw or nutrunners:
Reaction forces depend on tool setting and joint characteristics. The ability to bear reaction forces depends on the operator's strength and posture. Adapt the torque setting to the operator's strength and posture and use a torque arm or reaction bar if the torque is too high.
- Use dust extraction system or mouth protection mask in dusty environments.

Operating instructions

Tightening torque

The tightening torque attained depends on the air pressure, tightening time and bolted joint in question. Extension pieces and worn sockets will reduce the effective tightening torque. Oversized power sockets (diameter and or length) will overload the impact mechanism and reduce the life of vital parts as the impact mechanism. The impact wrench must be used within the specified torque range. **Never exceed the recommended maximum tightening torque.**

Test methods

Measurement using a hydraulic Torque Tension tester is recommended for testing tool performance, see Test data.

Maintenance

Service instructions

Overhaul and preventive maintenance are recommended at regular intervals once a year or after max. 100 000 tightening operations at the latest, whichever comes first. More frequent overhauls may be required if the machine is used for heavy-duty applications. If the machine fails to function correctly, it must be decommissioned immediately for inspection.

The strainer at the air inlet must be cleaned regularly in order to prevent clogging due to contamination. The machine capacity will otherwise be reduced.

All parts must be cleaned thoroughly during overhaul work and defective or worn parts must be replaced

It is important to ensure that the threaded connections on the machine are tightened properly; i.e. in accordance with the specifications in the exploded views. Lubricate the threads with grease prior to fitting.

ⓘ All O-rings must be greased prior to assembly.

When the machine is in constant operation, installation of an Atlas Copco DIM oil mist lubricating device or a Dosol type single point lubricating device is recommended.

Impact mechanism

Check the specified wear limits and replace all parts which exceed these. See Inspection.

ⓘ Recommended maximum wear limits for the clutch jaw, anvil and driver.

Rust protection and internal cleaning

Water in the compressed air, dust and wear particles cause rust and sticking of vanes, valves etc. An air filter should be installed close to the machine (see 'Air quality'). Before longer standstills, flush with oil (some drops) into the air inlet, run the machine for 5-10 seconds when absorbing the oil in a cloth.

How to optimize service and performance of your impact wrench

The service life of the impact mechanism is mainly dependent on:

- service intervals
- air pressure
- tightening time/torque
- number of tightening
- socket/bolt size
- socket length

Service intervals

Shorter service intervals with cleaning and lubrication of the impact parts will improve the function and reduce the wear. Follow our service recommendations.

Air pressure, tightening time/torque and number of tightening

It is obvious that wear will increase with increased air pressure, longer tightening time/higher torque and number of tightening.

A tightening time of 1-5 seconds is recommended. The Skidmore-Wilhelm table in Test data can be used as a guide for max. tightening time.

Longer tightening or loosening times will increase wear, producing malfunction and risk of breakage.

Socket and bolt size

Each impact wrench covers a certain bolt size range. The impact mechanism parts have been designed for good durability in combination with the recommended standard socket/bolt size.

Usage of oversized sockets/bolts will increase premature wear and risk of breakage.

If frequent square drive breakages occur and different square drive sizes are available, use the largest size.

Long sockets/extensions

It is better to use extensions + standard socket instead of long or extra long sockets as the lower inertia /mass of the extension will give less stress on the impact mechanism. However an extension will reduce the applied torque to some degree.

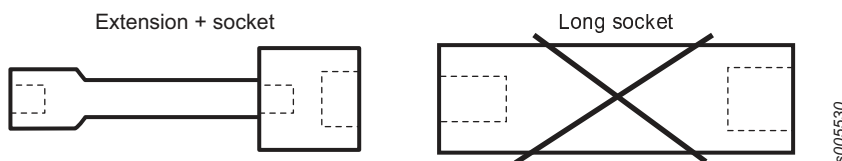

Recommendations for maximum socket / bolt size

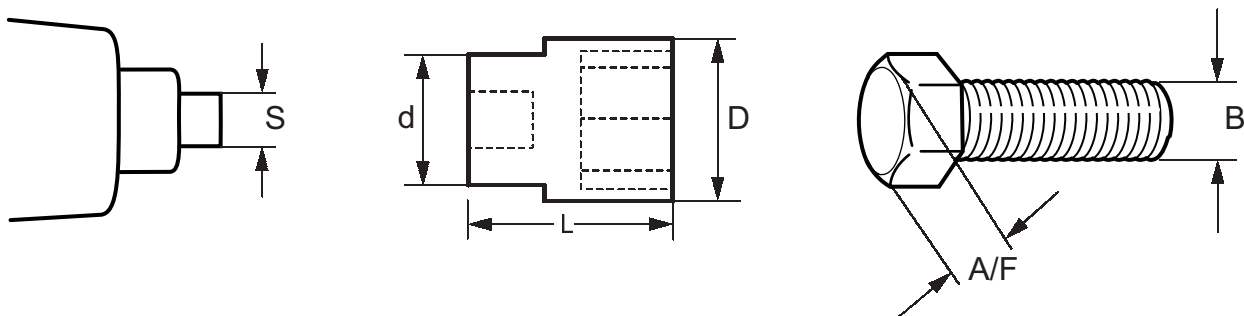

Drive S	Socket size d (max)	Socket length L (max)	Socket size D (max)	Socket opening A/F (max)	Bolt size B (max)
1"	54mm	65mm	57mm	36mm (1 3/8")	M24 (1")

Dismantling/ Assembling

Symbols

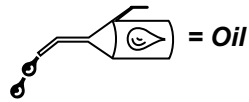
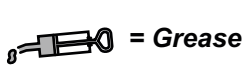

s011130

Bushing

Dismantling

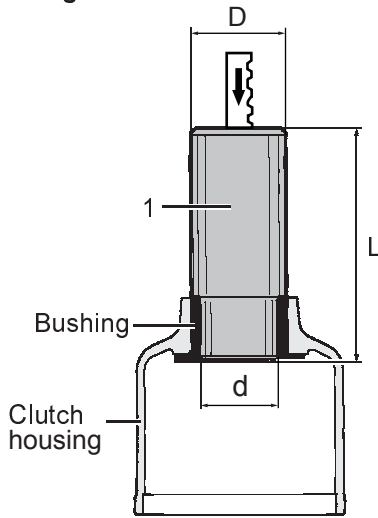

Assembling

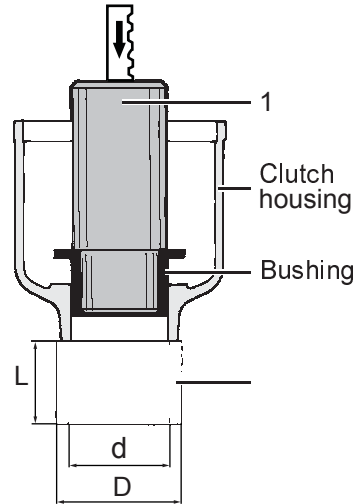

s000190

Ref. No.	Ordering No.	Qty	Description	Remark / Included in Service kit
1		1	Mandrel	L=100mm, D=39mm, d=31.5mm
2	4080 0207 02	1	Support ring	L=50mm, D=51mm, d=41mm

Motor

Dismantling

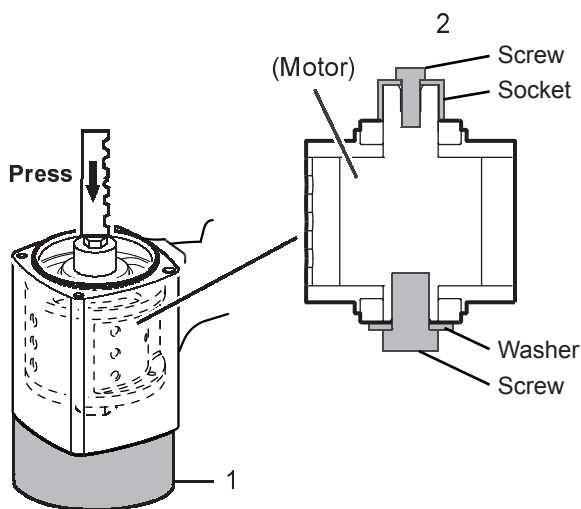

Assembling

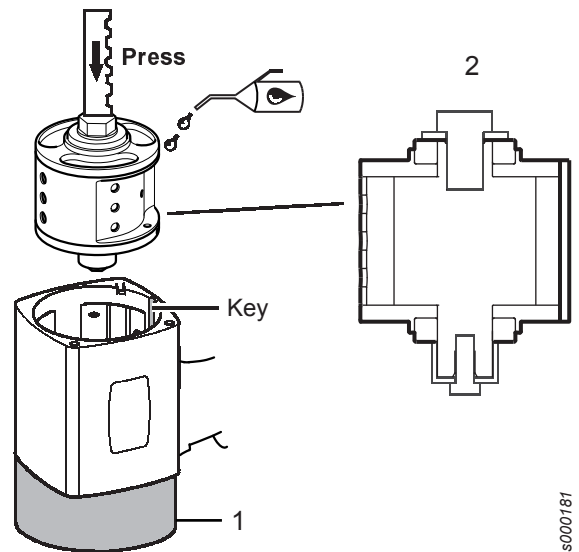

s000181

Ref. No.	Ordering No.	Qty	Description	Remark / Included in Service kit
1	4080 0206 08	1	Mandrel	

Ref. No.	Ordering No.	Qty	Description	Remark / Included in Service kit
2	4080 1331 82	1	Motor service tool	4pcs

Motor bearings

Dismantling

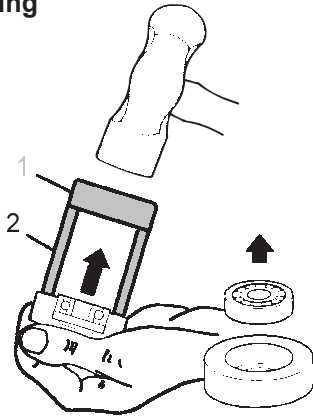

Assembling

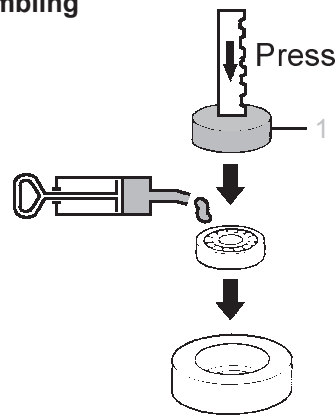

Ref. No.	Ordering No.	Qty	Description	Remark / Included in Service kit
1	4080 0208 03	1	Plate	
2	4080 0206 07	1	Mandrel	

Inspection

Inspection for wear on impact parts

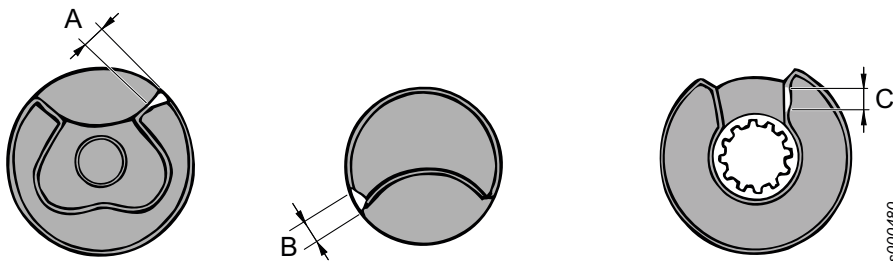

Wear limits

Anvil A (max)	Clutch jaw B (max)	Driver C (max)
2.3 mm	2.3 mm	2.9 mm

Inspection of silencer

Change or clean the filters regularly. Clogged filters will reduce power output.

Inspection of motor parts

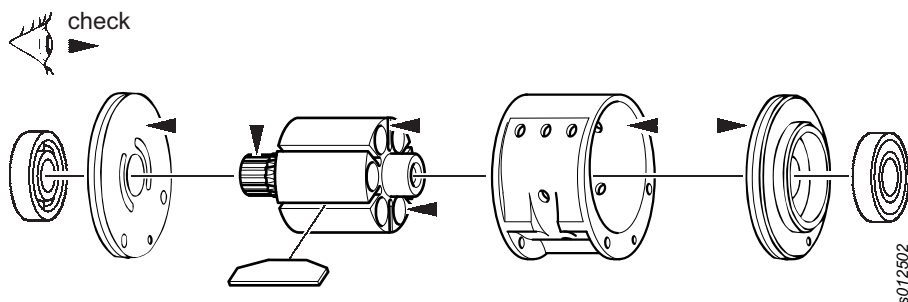

- **Clean all parts** before inspection.
- **End plates:** Check that they not are scored or scratched. If these are shallow, polish with fine grinding paste against a face plate. Clean thoroughly.
- **Rotor:** Check that the end faces do not have any marks or burrs. Check that the splines are not worn or cracked. Check that there are no cracks at the holes for the plugs.
- **Cylinder:** Check that the bore is not scored or scratched. If these are shallow, polish with a fine grinding cloth. Clean thoroughly.

Lubrication

Lubrication guide

Brand	General purpose grease	Impact mechanism	Air and motor lubrication
BP	Energrease LS-EP2		Energol E46
Castrol	Spheerol EP L2		
Esso	Beacon EP2		Arox EP46
Q8	Rembrandt EP2		Chopin 46
Mobil	Mobilegrease XHP 222		Almo oil 525
Shell	Alvania EP2	Alvania Grease RL 2	Torcula 32
Texaco	Multifak EP2		Aries 32
Molycote			

Lubrication of impact mechanism

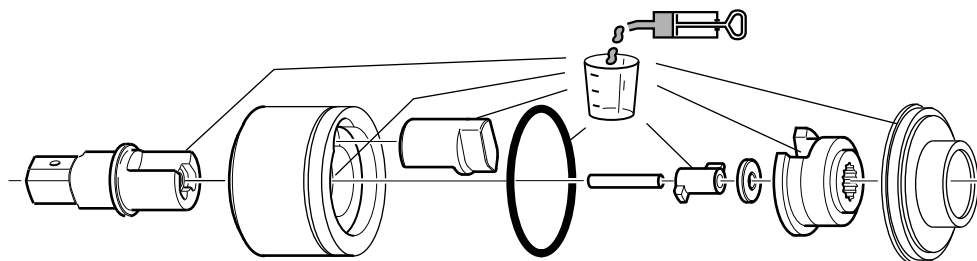

Lubrication of motor parts

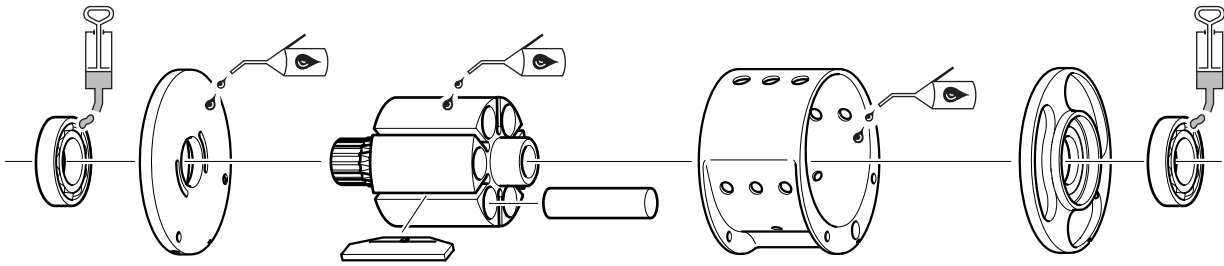

s001000

Note

- No grease is needed for protected Ball bearings (ex. 2Z).
- Where oil is needed, apply only a thin layer.

Test data

Test on Tension tester (Skidmore-Wilhelm)

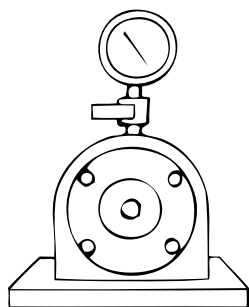

s005371

Test performance:

Test equipment according to the tables below.

Assemble selected test bolt set in the tester ensuring that threads and pressure faces are well lubricated with Molycote Longterm W2 or similar molybdenum disulphide lubricant.

Make 3 tightenings and check that the minimum tension can be reached.

Test conditions:

Air pressure = 6.3 bar (90 psi) dynamic.

Test result

Model	Tester	Bolt size	Min. Tension	Tightening time	Min. * Free speed	Test hose (3 m) inner diam.
LMS08 HR10	Skidmore-Wilhelm model J	5/8"	34 kN	2 s	11000 rpm	6.3 mm (1/4")
LMS08 HR42	Skidmore-Wilhelm model J	5/8"	21 kN	2 s	11000 rpm	6.3 mm (1/4")
LMS08 SR10	Skidmore-Wilhelm model J	5/8"	33 kN	2 s	11000 rpm	6.3 mm (1/4")
LMS08 SR42	Skidmore-Wilhelm model J	5/8"	19 kN	2 s	11000 rpm	6.3 mm (1/4")
LMS18 HR10	Skidmore-Wilhelm model J	7/8"	39 kN	2 s	7000 rpm	10 mm (3/8")
LMS18 HR13	Skidmore-Wilhelm model J	7/8"	53 kN	2 s	7000 rpm	10 mm (3/8")
LMS28 HR13	Skidmore-Wilhelm model RL	3/4"	83 kN	2 s	8000 rpm	10 mm (3/8")
LMS38 HR13	Skidmore-Wilhelm model RL	1"	110 kN	2 s	6800 rpm	10 mm (3/8")
LMS48 HR20	Skidmore-Wilhelm model RL	1"	161 kN	3 s	5500 rpm	12.5 mm (1/2")
LMS58 HR20	Skidmore-Wilhelm model H	1 1/4"	260 kN	3 s	4700 rpm	12.5 mm (1/2")
LMS58 HR25	Skidmore-Wilhelm model H	1 1/4"	270 kN	3 s	4700 rpm	12.5 mm (1/2")
LMS68	Skidmore-Wilhelm model H	1 1/2"	470 kN	4 s	4200 rpm	16 mm (5/8")
LMS88	Skidmore-Wilhelm model K	2"	660 kN	6 s	3200 rpm	16 mm (5/8")

* = If Free speed is to low: check silencer for clogged filters.

Exploded views/tables

Spare parts

Parts without ordering number are not delivered separately for technical reasons.

The use of other than genuine Atlas Copco replacement parts may result in decreased tool performance and increased maintenance and may, at the company option, invalidate all warranties.

Clutch housing

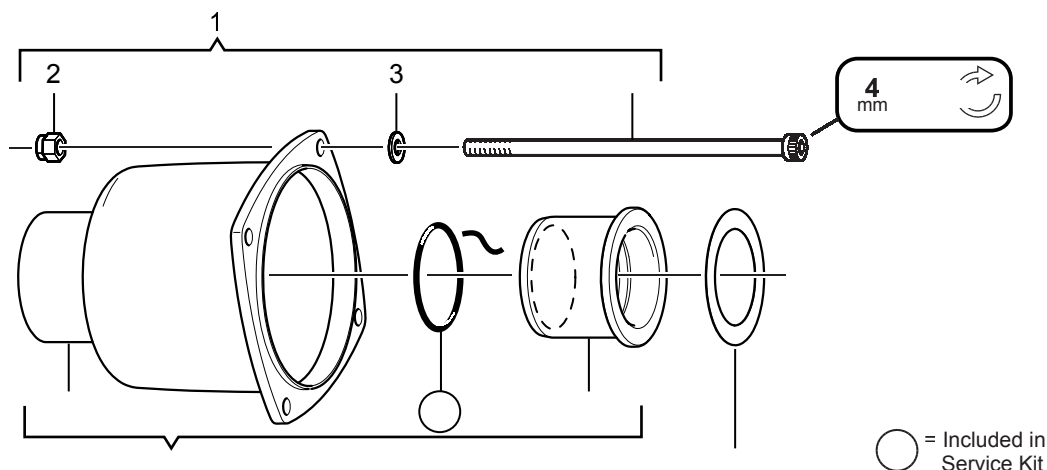

Ref. No.	Ordering No.	Qty	Description	Remark / Included in Service kit
1(2-4)	4250 2897 90	1	Screw, kit	
2	-	4	Lock nut	M5x6.8 Black, AF8
3	-	4	Washer	5.3x10x1
4	-	4	Screw	M5x117
5(6-8)	4250 2876 90	1	Clutch housing, compl.	
6	-	1	Clutch housing	
7	0663 2100 05	1	O-ring	32x2.4 / Service kit 4081 0445 90
8	4250 2875 00	1	Bushing	
9	-	1	Shim	32x45x0.3 / Small parts kit 4082 0001 90
		1	Mandrel	Ø31.5/39 mm. Service tool for dismantling/ assembling of Bushing. For further information, pls see Service instructions
	4080 0207 02	1	Support ring	Ø41/45 x 60 mm. Service tool for assembling of Bushing. For further information, pls see Service instructions
	0902 0112 00	1	Allen key	4 mm. Accessory included. Service tool.

Impact mechanism

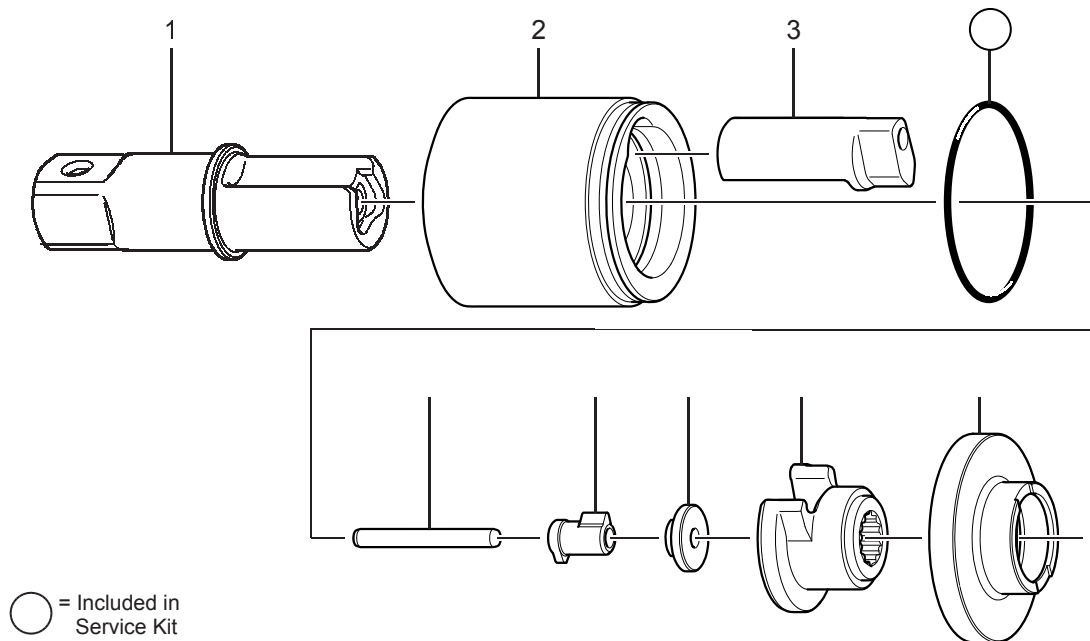

0000090

Ref. No.	Ordering No.	Qty	Description	Remark / Included in Service kit
1	4250 2849 00	1	Anvil	1" Square
2	4250 2874 00	1	Hammer	
3	4250 2873 00	1	Clutch jaw	
4	-	1	O-ring	62x2.5 / Service kit 4081 0445 90
5	4250 1105 02	1	Pin	
6	4250 1104 00	1	Cam	
7	4250 2391 00	1	Washer	
8	4250 2872 00	1	Driver	
9	4250 2691 00	1	Cover	

Motor

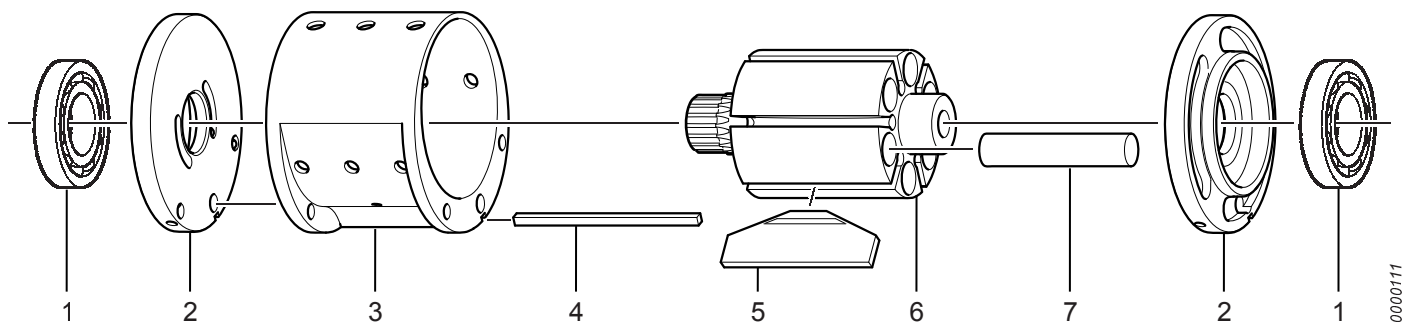

0000111

Ref. No.	Ordering No.	Qty	Description	Remark / Included in Service kit
1	0502 1504 00	2	Ball bearing	16004
2	4250 1569 01	2	End plate	
3	4250 1572 00	1	Cylinder	
4	4250 2998 00	1	Key	
5	4250 1573 96	1	Vane, kit	6 pcs
6	4250 1696 01	1	Rotor	
7	4250 1567 90	1	Plug kit	6 pcs
	4080 1331 82	1	Motor service tool	Accessory included. Service tool for dismantling/ assembling of Motor. For further information, pls see Service instructions
	4080 0206 08	1	Mandrel	Ø75/85 mm. Service tool for dismantling/ assembling of Motor. For further information, pls see Service instructions
	4080 0208 03	1	Plate	Ø68 x 10 mm. Service tool for dismantling/ assembling of Motor bearings. For further information, pls see Service instructions
	4080 0206 07	1	Mandrel	Ø55/65 mm. Service tool for dismantling of Motor bearings. For further information, pls see Service instructions

Motor housing

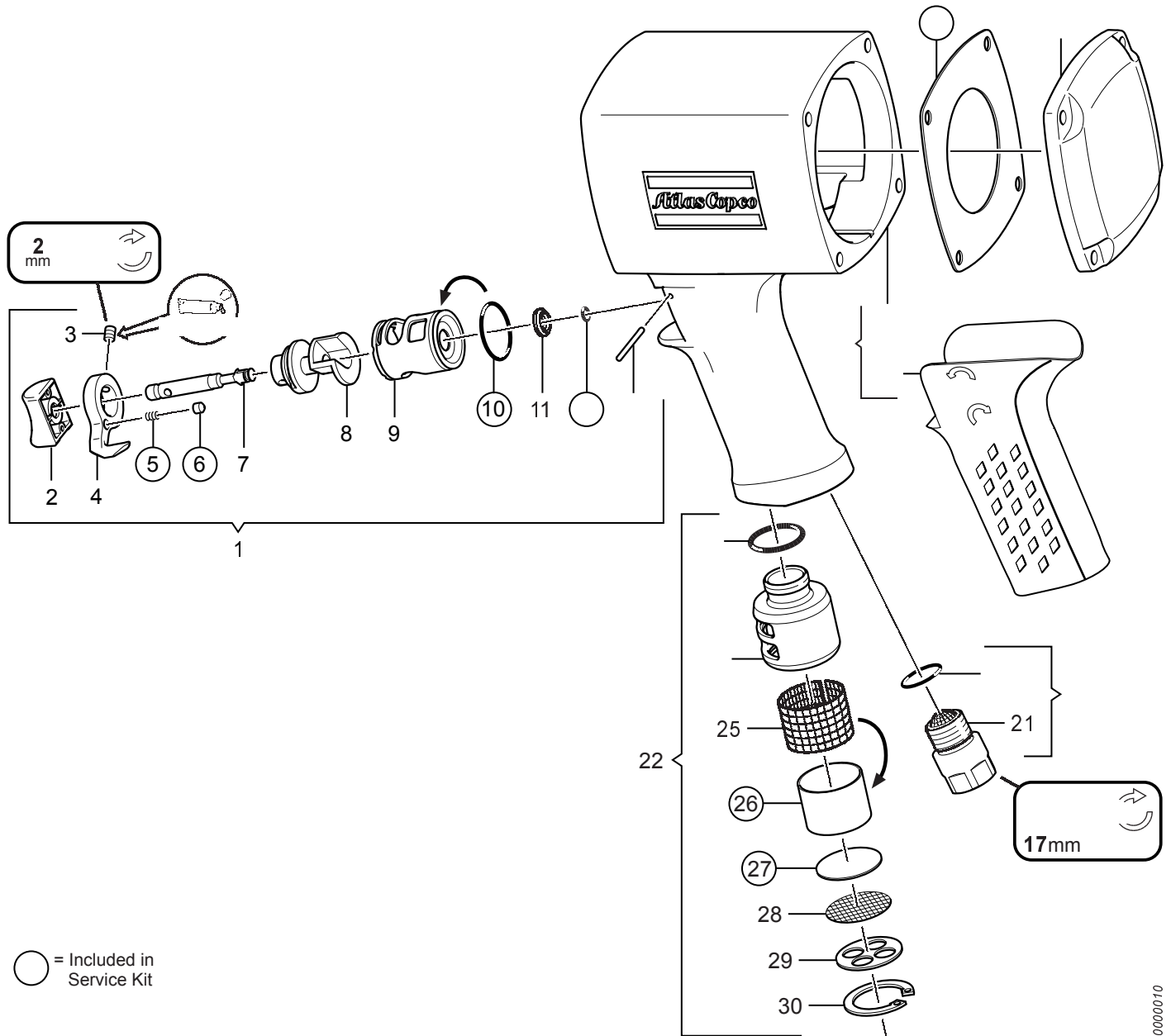

Ref. No.	Ordering No.	Qty	Description	Remark / Included in Service kit
1(2-13)	4250 2035 60	1	Reversing valve, compl.	
2	4250 1660 00	1	Push button	
3	-	1	Stop screw	M4x5 / Small parts kit 4082 0001 90
4	4250 1828 01	1	Reversing knob	
5	-	1	Spring	Service kit 4081 0445 90
6	-	1	Retainer pin	Service kit 4081 0445 90
7	4250 1659 02	1	Valve pin	
8	-	1	Reversing valve	
9	-	1	Liner	
10	-	1	O-ring	20.35x1.78 / Service kit 4081 0445 90
11	4250 1935 04	1	Washer	
12	-	1	O-ring	2.8x1.6 / Service kit 4081 0445 90
13	-	1	Pin	2x24.8 / Small parts kit 4082 0001 90
14(15-16)	4250 2790 00	1	Motor housing, compl.	
15	4250 1939 93	1	Rubber cover	
16	-	1	Motor housing	
17	-	1	Gasket	Service kit 4081 0445 90
18	4250 2791 00	1	Cover	
19(20-21)	4250 2039 90	1	Adapter, compl.	G3/8". With NPT-thread (for the US, Canada) 4250 2039 91
20	-	1	O-ring	15.1x1.6 / Small parts kit 4082 0001 90
21	-	1	Adapter	

Ref. No.	Ordering No.	Qty	Description	Remark / Included in Service kit
22(23-30)	4250 2796 80	1	Silencer, compl.	
23	-	1	O-ring	15.08x2.62 / Small parts kit 4082 0001 90
24	-	1	Silencer	
25	-	1	Net	
26	-	1	Filter	Service kit 4081 0445 90
27	-	1	Filter	Service kit 4081 0445 90
28	-	1	Net	
29	-	1	Cover	
30	-	1	Circlip	SGH 27 / Small parts kit 4082 0001 90

Service Kits

Service kit — Clutch housing / Impact mechanism / Motor housing

Ordering No. 4081 0445 90

Ordering No.	Qty	Description	Remark / Included in Service kit
0663 2100 05	1	O-ring	32x2.4
-	1	O-ring	62x2.5
-	1	Spring	
-	1	Retainer pin	
-	1	O-ring	20.35x1.78
-	1	O-ring	2.8x1.6
-	1	Gasket	
-	1	Filter	
-	1	Filter	

Service kits are designed for a variety of products. This Service kit may contain more parts than listed in the table and parts might remain unused.

Small-parts kit — Clutch housing / Motor housing

Ordering No. 4082 0001 90

Ordering No.	Qty	Description	Remark / Included in Service kit
-	1	Shim	32x45x0.3
-	1	Stop screw	M4x5
-	1	Pin	2x24.8
-	1	O-ring	15.1x1.6
-	1	O-ring	15.08x2.62
-	1	Circlip	SGH 27

Service kits are designed for a variety of products. This Service kit may contain more parts than listed in the table and parts might remain unused.

Service Tools

Service Tools

For motor

Section	Ordering No.	Description	Remark
Bushing		Mandrel	L=100mm, D=39mm, d=31.5mm
Bushing	4080 0207 02	Support ring	L=50mm, D=51mm, d=41mm
Motor	4080 0206 08	Mandrel	
Motor	4080 1331 82	Motor service tool	4pcs
Tuleja		Mandrel	L=100mm, D=39mm, d=31.5mm
Tuleja	4080 0207 02	Support ring	L=50mm, D=51mm, d=41mm
Silnik	4080 0206 08	Mandrel	
Silnik	4080 1331 82	Motor service tool	4pcs
Clutch housing		Mandrel	Ø31.5/39 mm Service tool for dismantling/ assembling of Bushing. For further information, pls see Service instructions
Clutch housing	0902 0112 00	Allen key	4 mm Accessory included. Service tool.

Accessories included

Cup



Ref. No.	Ordering No.	Qty	Description	Remark / Included in Service kit
	4080 1358 00		Cup	For filling Impact mechanism with grease, see service instruction

Motor service tool



Ref. No.	Ordering No.	Qty	Description	Remark / Included in Service kit
	4080 1331 82		Motor service tool	For assembly and disassembly of motor into casing, see service instruction

Suspension yoke

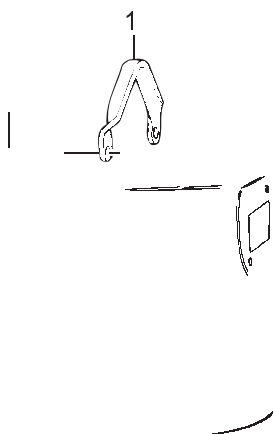

Ref. No.	Ordering No.	Qty	Description	Remark / Included in Service kit
1	4250 0872 00	1	Suspension yoke	Can be adjusted to fit different hole patterns.

