

LMS68 HR25



Printed Matter No. 9836 6501 00

Impact Wrench

Valid from Serial No. A2520001
2012-12

Product Instructions



	 WARNING



General information

⚠ WARNING

- Read all safety warnings and all instructions.
Failure to follow the warnings and instructions may result in electric shock, fire and/or serious injury.
- Save all warnings and instructions for future reference.

Safety signal words

The safety signal words Danger, Warning, Caution, and Notice have the following meanings:

DANGER	DANGER indicates a hazardous situation which, if not avoided, will result in death or serious injury.
WARNING	WARNING indicates a hazardous situation which, if not avoided, could result in death or serious injury.
CAUTION	CAUTION, used with the safety alert symbol, indicates a hazardous situation which, if not avoided, could result in minor or moderate injury.
NOTICE	NOTICE is used to address practices not related to personal injury.

Warranty

Contact the Atlas Copco sales representative within your area to claim a product. Warranty will only be approved if the product has been installed, operated and overhauled according to the Operating Instructions.

Please also see the delivery conditions applied by the local Atlas Copco company.

ServAid

ServAid is a utility for providing updated product information concerning:

- Safety instructions
- Installation, Operation and Service instructions
- Exploded views

ServAid facilitates the ordering process of spare parts, service tools and accessories for the product of your choice. It is continuously updated with information of new and redesigned products.

You can use ServAid to present content in a specific language, provided translations are available, and to display information about obsolete products. ServAid offers an advanced search functionality of our entire product range.

ServAid is available on DVD and on the web:

<http://servaidweb.atlascopco.com>

For further information contact your Atlas Copco sales representative or e-mail us at:

servaid.support@se.atlascopco.com

Further information

For further information concerning this product, please see Printed Matter No. -, available in ServAid on the web.

Overview

Applications

This powerful, high-speed impact wrench (LMS) is typically used for loosening applications where fast tightening or disassembly is needed.

Service intervals

Service recommendations

Overhaul and preventive maintenance is recommended at regular intervals. If the machine is not working properly, it should immediately be taken out of operation for inspection. At the overhauls, all parts should be cleaned accurately and defective or worn parts should be replaced.

Installation requirement

General

The machine is designed for a working pressure (e) of 6.3 - 7 bar (max.) = 630 - 700 kPa (90 - 102 psi).

If the compressed air line pressure is higher than 7 bar it is preferable reduced with a pressure regulator of the type Atlas Copco REG.

The Atlas Copco Air Line Test equipment is suitable for checking of air pressure and airflow at the installation point (please see AirLine Accessories in our main catalogue).

The machine can operate at a lower working pressure. Maximum torque will be reduced at lower pressures.

- ⓘ **If frequent used for tightening or loosening that need longer time than 3-5 seconds, a larger wrench should be used. Otherwise the servicelife of the impact mechanism will be reduced.**

To avoid pressure drop use recommended hosesize, length, and connections. For more information please read Atlas Copco Airline Installations, Ordering No. 9833 1191 01.

Air quality

- For optimum performance and maximum machine life we recommend the use of compressed air with a maximum dew point of +10°C. We also recommend the installation of an Atlas Copco refrigeration-type air dryer.
- Use a separate air filter of type Atlas Copco FIL. This filter removes solid particles larger than 15 microns and also removes more than 90 % of liquid water. The filter must be installed as close as possible to the machine/equipment and prior to any other air preparation unit such as REG or DIM (please see Air Line Accessories in our main catalogue). Blow out the hose before connecting.

Models which need air lubrication:

- The compressed air must contain a small quantity of oil.
We strongly recommend that you install an Atlas Copco oil-fog lubricator (DIM). This should be set according to air consumption by the air line tool according to the following formula:

$L = \text{Air consumption (litre/s)}$

(May be found in our sales literature).

$D = \text{Number of drops per min (1 drop} = 15 \text{ mm}^3)$

$L * 0.2 = D$

this applies to the use of long work cycle air line tools. A single point lubricator type Atlas Copco Dosol can also be used for tools with short running cycles.

Information about Dosol settings may be found under Air Line Accessories in our main catalogue.

Lubrication-free models:

- In the case of lubrication-free tools it is up to the customer to decide on the peripheral equipment to be used. However, it is no disadvantage if the compressed air contains a small quantity of oil e.g. supplied from a fog lubricator (DIM) or Dosol system. This does not apply to turbine tools, which should be kept oil free.

Installation proposal

Choosing the correct couplings, hose and clamps can be a troublesome digging into details. To save your time and to ensure correct capacity of the airline installation, from the tapping point to the tool, we offer you an installation proposal.

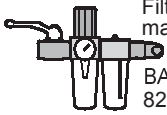

Filtered, regulated and oil fog lubricated air for a
max. air flow of 22 l/s

BALL VALVE + MIDI F/RD 15 + ERGOQIC 10
8202 0829 11

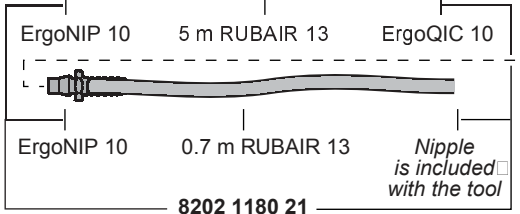

Ergonomics

Ergonomic guidelines

- 1) Take frequent breaks and change work positions frequently.
- 2) Adapt the workstation area to your needs and the work task.
 - Adjust for convenient reach range by determining where parts or tools should be located to avoid static load.
 - Use workstation equipment such as tables and chairs appropriate for the work task.
- 3) Avoid work positions above shoulder level or with static holding during assembly operations.
 - When working above shoulder level, reduce the load on the static muscles by reducing the weight of the tool, using for example torque arms, hose reels or weight balancers. You can also reduce the load on the static muscles by holding the tool close to the body.
 - Make sure to take frequent breaks.
 - Avoid extreme arm or wrist postures, particularly for operations requiring a degree of force.
- 4) Adjust for convenient field of vision by minimizing movement of the eyes and head during the work task.
- 5) Use the appropriate lighting for the work task.
- 6) Select the appropriate tool for the work task.
- 7) Use ear protection equipment in noisy environments.
- 8) Use high-quality inserted tools or consumables to minimize exposure to excessive levels of vibrations.
- 9) Minimize exposure to reaction forces.
 - When cutting:
A cut-off wheel can get stuck if the wheel is either bent or if it is not guided properly. Make sure to use correct flanges for cut-off wheels and avoid bending the wheel during cut-off operation.
 - When drilling:
The drill might stall when the drill bit breaks through. Make sure you use support handles if the stall torque is too high. The safety standard ISO11148 part 3 recommends to use something to absorb the reaction torque above 10 Nm for pistol grip tools and 4 Nm for straight tools.
 - When using direct driven screw or nutrunners:
Reaction forces depend on tool setting and joint characteristics. The ability to bear reaction forces depends on the operator's strength and posture. Adapt the torque setting to the operator's strength and posture and use a torque arm or reaction bar if the torque is too high.
- 10) Use dust extraction system or mouth protection mask in dusty environments.

Operating instructions

Tightening torque

The tightening torque attained depends on the air pressure, tightening time and bolted joint in question. Extension pieces and worn sockets will reduce the effective tightening torque. Oversized power sockets (diameter and or length) will overload the impact mechanism and reduce the life of vital parts as the impact mechanism. The impact wrench must be used within the specified torque range. **Never exceed the recommended maximum tightening torque.**

Test methods

Measurement using a hydraulic Torque Tension tester is recommended for testing tool performance, see Test data.

Maintenance

Service instructions

Overhaul and preventive maintenance are recommended at regular intervals once a year or after max. 100 000 tightening operations at the latest, whichever comes first. More frequent overhauls may be required if the machine is used for heavy-duty applications. If the machine fails to function correctly, it must be decommissioned immediately for inspection.

The strainer at the air inlet must be cleaned regularly in order to prevent clogging due to contamination. The machine capacity will otherwise be reduced.

All parts must be cleaned thoroughly during overhaul work and defective or worn parts must be replaced

It is important to ensure that the threaded connections on the machine are tightened properly; i.e. in accordance with the specifications in the exploded views. Lubricate the threads with grease prior to fitting.

ⓘ All O-rings must be greased prior to assembly.

The motor has to be lubricated with oil from the handle's oil chamber unless a permanent air lubrication device is installed. Check daily to ensure that the oil chamber is filled and that the discharge air contains a sufficient amount of oil. See Handle.

When the machine is in constant operation, installation of an Atlas Copco DIM oil mist lubricating device or a Dosol type single point lubricating device is recommended.

Impact mechanism

Check the specified wear limits and replace all parts which exceed these. See Inspection.

ⓘ Recommended maximum wear limits for the clutch jaw, anvil and driver.

Rust protection and internal cleaning

Water in the compressed air, dust and wear particles cause rust and sticking of vanes, valves etc. An air filter should be installed close to the machine (see 'Air quality'). Before longer standstills, flush with oil (some drops) into the air inlet, run the machine for 5-10 seconds when absorbing the oil in a cloth.

How to optimize service and performance of your impact wrench

The service life of the impact mechanism is mainly dependent on:

- service intervals
- air pressure
- tightening time/torque
- number of tightening
- socket/bolt size
- socket length

Service intervals

Shorter service intervals with cleaning and lubrication of the impact parts will improve the function and reduce the wear. Follow our service recommendations.

Air pressure, tightening time/torque and number of tightening

It is obvious that wear will increase with increased air pressure, longer tightening time/higher torque and number of tightening.

A tightening time of 1-5 seconds is recommended. The Skidmore-Wilhelm table in Test data can be used as a guide for max. tightening time.

Longer tightening or loosening times will increase wear, producing malfunction and risk of breakage.

Socket and bolt size

Each impact wrench covers a certain bolt size range. The impact mechanism parts have been designed for good durability in combination with the recommended standard socket/bolt size.

Usage of oversized sockets/bolts will increase premature wear and risk of breakage.

If frequent square drive breakages occur and different square drive sizes are available, use the largest size.

Long sockets/extensions

It is better to use extensions + standard socket instead of long or extra long sockets as the lower inertia /mass of the extension will give less stress on the impact mechanism. However an extension will reduce the applied torque to some degree.

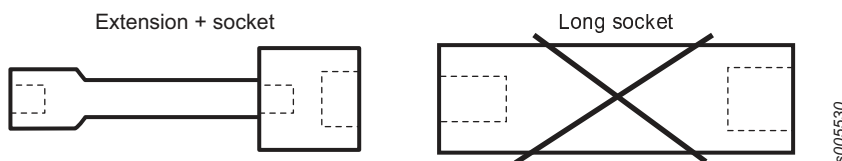

Recommendations for maximum socket / bolt size

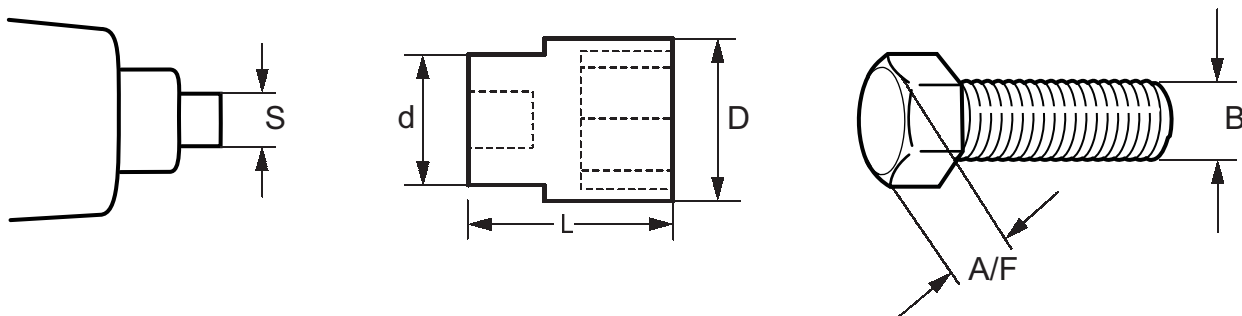

Drive S	Socket size d (max)	Socket length L (max)	Socket size D (max)	Socket opening A/F (max)	Bolt size B (max)
1"	54mm	75mm	72mm	48mm (1 7/8")	M32 (1 1/4")

Dismantling/ Assembling

Symbols

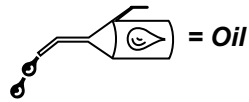
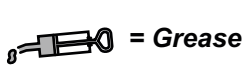

s011130

Motor housing vs. Handle

Dismantling order

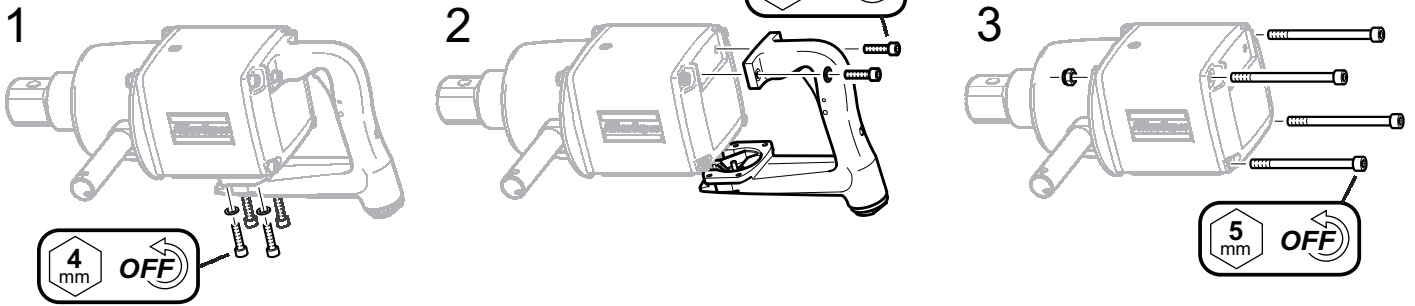

Assembling order

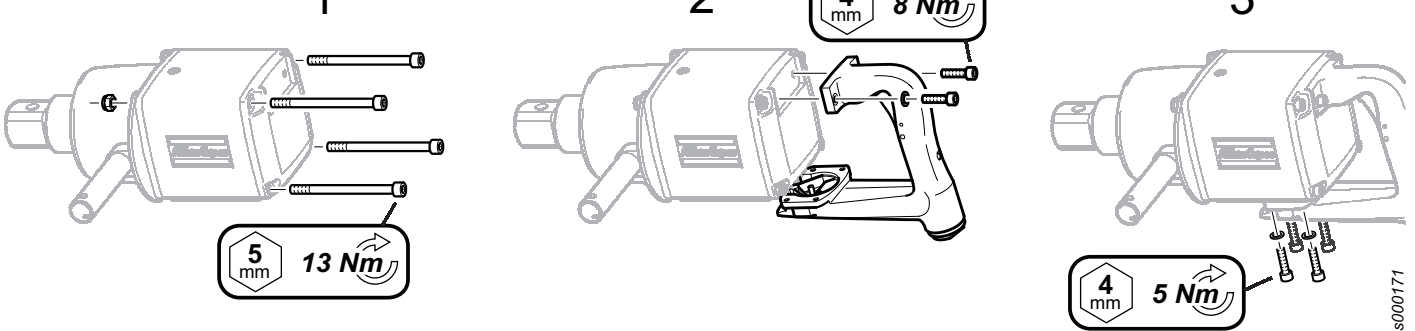

s000171

Bushing

Dismantling

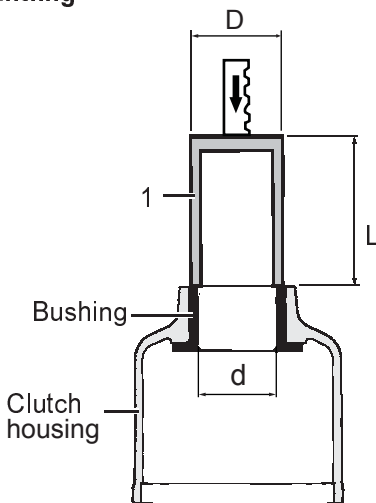

Assembling

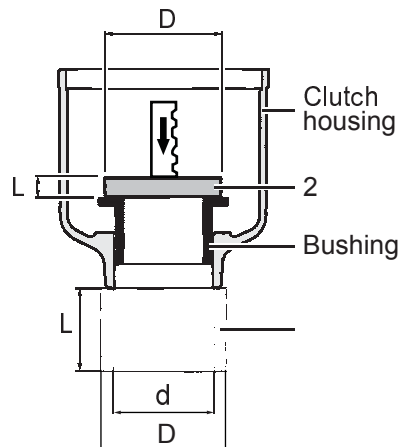

s000191

Ref. No.	Ordering No.	Qty	Description	Remark / Included in Service kit
1	4080 0182 14	1	Mandrel	L=120mm, D=47mm
2	-	1	Plate	L=15mm, D=56mm

Ref. No.	Ordering No.	Qty	Description	Remark / Included in Service kit
3	4080 0207 07	1	Support ring	L=83mm, D=53mm, d=50mm

Motor

Dismantling

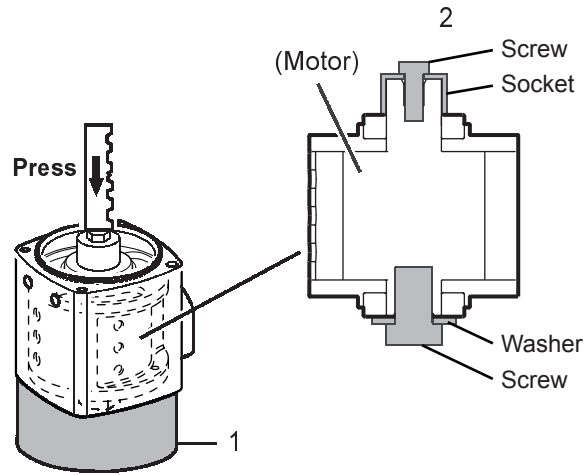

Assembling

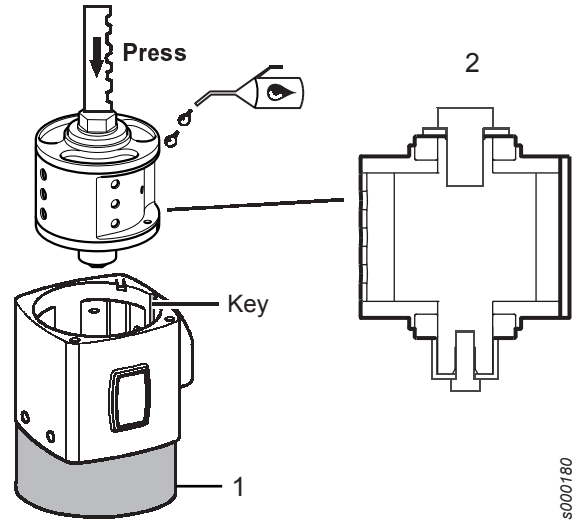

s000180

Ref. No.	Ordering No.	Qty	Description	Remark / Included in Service kit
1	4080 0206 05	1	Mandrel	
2	4080 1331 81	1	Motor service tool	4pcs

Motor bearings

Dismantling

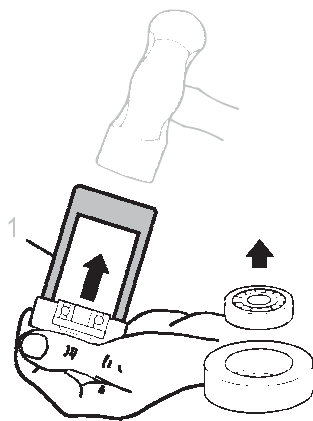

Assembling

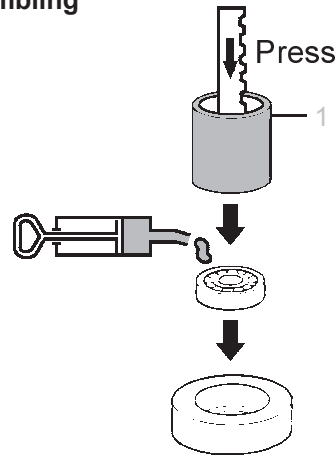

Ref. No.	Ordering No.	Qty	Description	Remark / Included in Service kit
1	4080 1332 00	1	Mandrel	

Valve and reversing valve

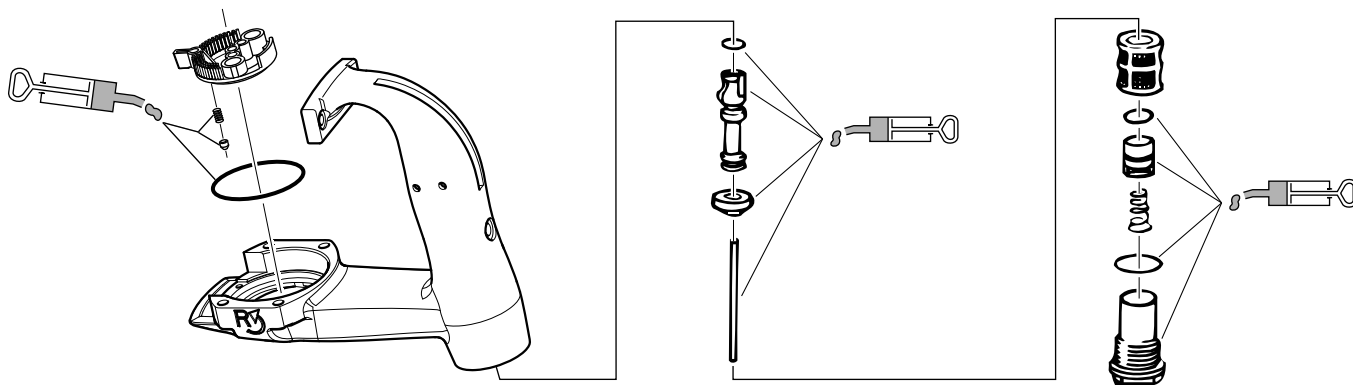

s011291

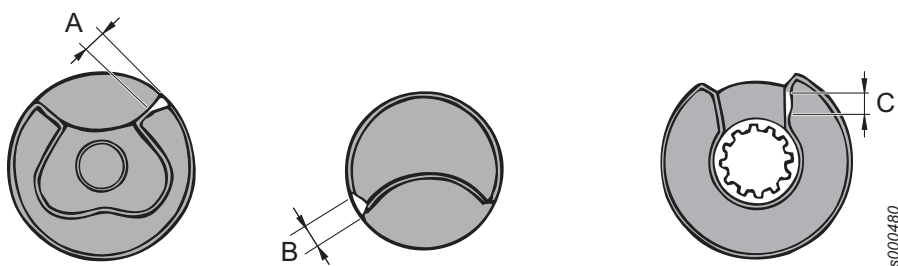

s000480

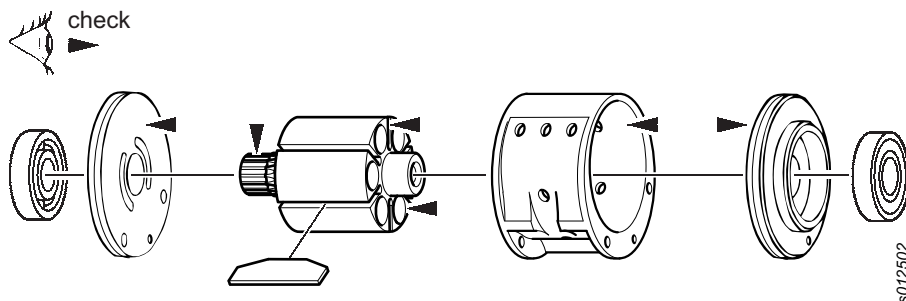

s012502

- **Clean all parts** before inspection.
- **End plates:** Check that they not are scored or scratched. If these are shallow, polish with fine grinding paste against a face plate. Clean thoroughly.

- **Rotor:** Check that the end faces do not have any marks or burrs. Check that the splines are not worn or cracked. Check that there are no cracks at the holes for the plugs.
- **Cylinder:** Check that the bore is not scored or scratched. If these are shallow, polish with a fine grinding cloth. Clean thoroughly.

Lubrication

Lubrication guide

Brand	General purpose grease	Impact mechanism	Air and motor lubrication
BP	Energrease LS-EP2		Energol E46
Castrol	Spheerol EP L2		
Esso	Beacon EP2		Arox EP46
Q8	Rembrandt EP2		Chopin 46
Mobil	Mobilegrease XHP 222		Almo oil 525
Shell	Alvania EP2	Alvania Grease RL 2	Torcula 32
Texaco	Multifak EP2		Aries 32
Molycote			

Filling of oil for Motor

Fill up with appr. 10ml of oil. Please see Lubrication guide for recommended oil.

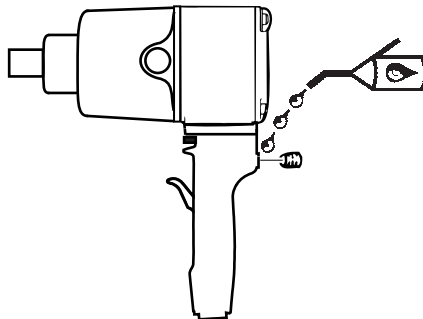

Lubrication of impact mechanism

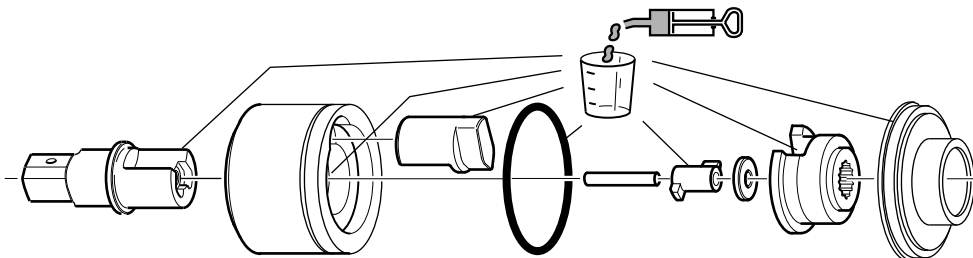

Lubrication of motor parts

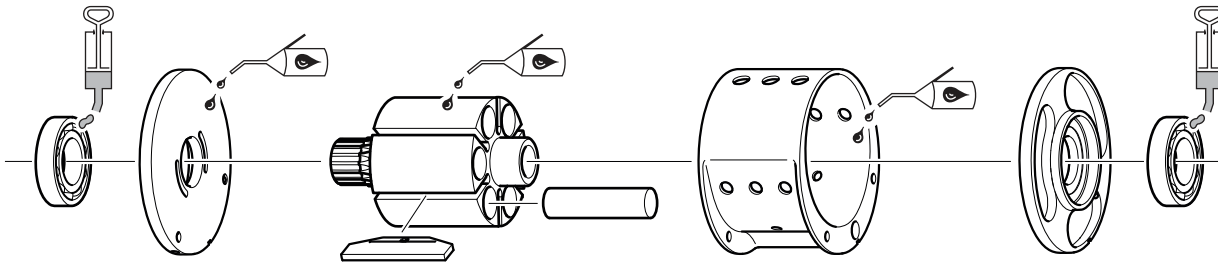

s001000

Note

- No grease is needed for protected Ball bearings (ex. 2Z).
- Where oil is needed, apply only a thin layer.

Test data

Test on Tension tester (Skidmore-Wilhelm)

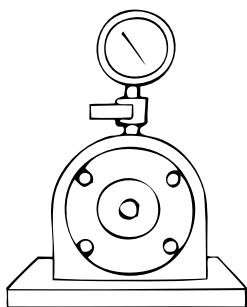

s005371

Test performance:

Test equipment according to the tables below.

Assemble selected test bolt set in the tester ensuring that threads and pressure faces are well lubricated with Molycote Longterm W2 or similar molybdenum disulphide lubricant.

Make 3 tightenings and check that the minimum tension can be reached.

Test conditions:

Air pressure = 6.3 bar (90 psi) dynamic.

Test result

Model	Tester	Bolt size	Min. Tension	Tightening time	Min. * Free speed	Test hose (3 m) inner diam.
LMS08 HR10	Skidmore-Wilhelm model J	5/8"	34 kN	2 s	11000 rpm	6.3 mm (1/4")
LMS08 HR42	Skidmore-Wilhelm model J	5/8"	21 kN	2 s	11000 rpm	6.3 mm (1/4")
LMS08 SR10	Skidmore-Wilhelm model J	5/8"	33 kN	2 s	11000 rpm	6.3 mm (1/4")
LMS08 SR42	Skidmore-Wilhelm model J	5/8"	19 kN	2 s	11000 rpm	6.3 mm (1/4")
LMS18 HR10	Skidmore-Wilhelm model J	7/8"	39 kN	2 s	7000 rpm	10 mm (3/8")
LMS18 HR13	Skidmore-Wilhelm model J	7/8"	53 kN	2 s	7000 rpm	10 mm (3/8")
LMS28 HR13	Skidmore-Wilhelm model RL	3/4"	83 kN	2 s	8000 rpm	10 mm (3/8")
LMS38 HR13	Skidmore-Wilhelm model RL	1"	110 kN	2 s	6800 rpm	10 mm (3/8")
LMS48 HR20	Skidmore-Wilhelm model RL	1"	161 kN	3 s	5500 rpm	12.5 mm (1/2")
LMS58 HR20	Skidmore-Wilhelm model H	1 1/4"	260 kN	3 s	4700 rpm	12.5 mm (1/2")
LMS58 HR25	Skidmore-Wilhelm model H	1 1/4"	270 kN	3 s	4700 rpm	12.5 mm (1/2")
LMS68	Skidmore-Wilhelm model H	1 1/2"	470 kN	4 s	4200 rpm	16 mm (5/8")
LMS88	Skidmore-Wilhelm model K	2"	660 kN	6 s	3200 rpm	16 mm (5/8")

* = If Free speed is to low: check silencer for clogged filters.

Exploded views/tables

Spare parts

Parts without ordering number are not delivered separately for technical reasons.

The use of other than genuine Atlas Copco replacement parts may result in decreased tool performance and increased maintenance and may, at the company option, invalidate all warranties.

Clutch housing

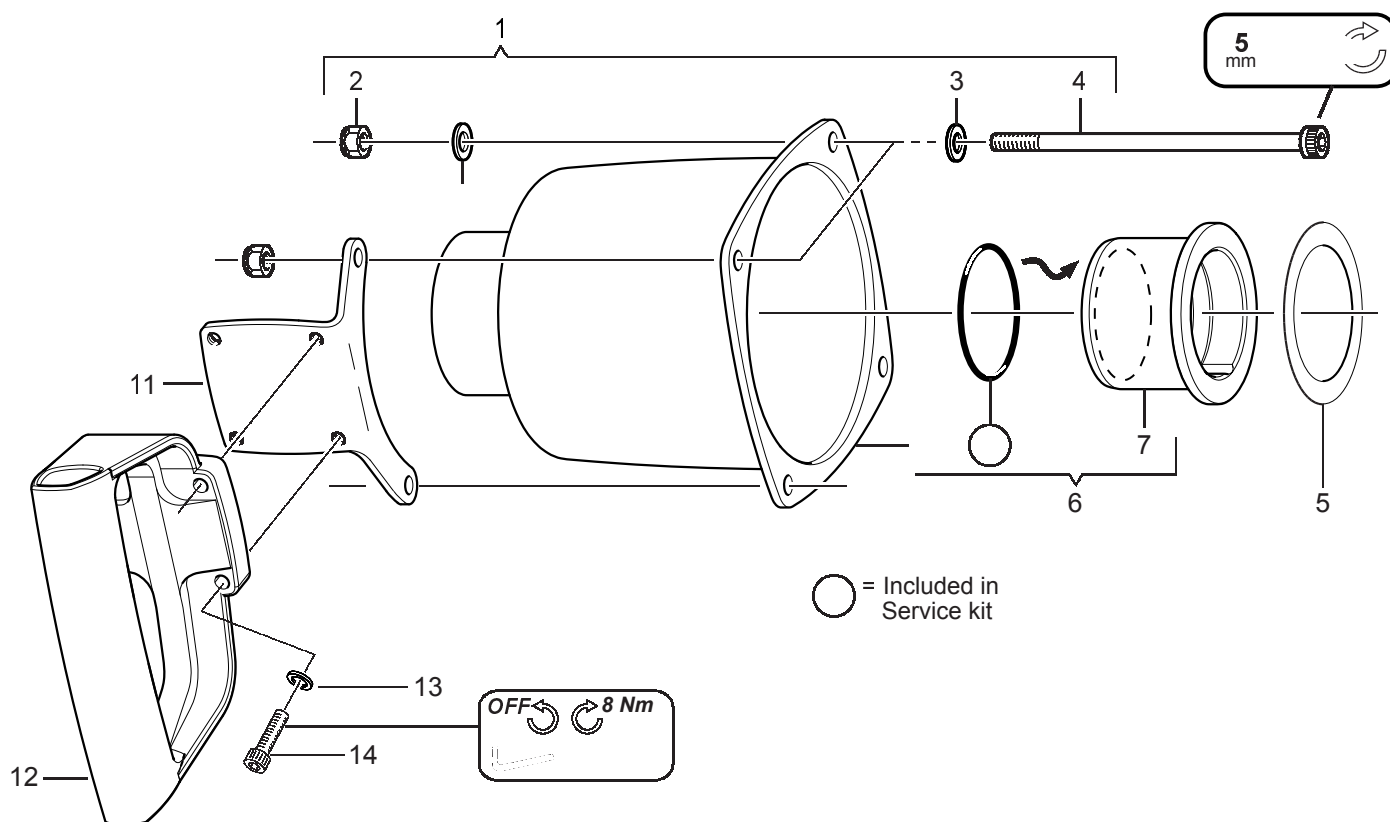

0000272

Ref. No.	Ordering No.	Qty	Description	Remark / Included in Service kit
1(2-4)	4250 2694 90	1	Screw, kit	
2	-	4	Lock nut	M6x8 Black, AF10
3	-	4	Washer	6.4x12x1.6
4	4250 2694 00	4	Screw	M6 6x128
5	-	1	Shim	45x55x0.2 / Small parts kit 4082 0051 90
6(7-9)	4250 2480 90	1	Clutch housing, compl.	
7	4250 2504 00	1	Bushing	
8	-	1	O-ring	42x2.5 / Service kit 4081 0442 90
9	-	1	Clutch housing	
10	0300 0276 79	2	Washer	6.4x12.3x3 / Small parts kit 4082 0051 90
11	4250 2518 02	1	Bracket	
12	-	1	Support handle	
13	-	8	Washer	5.3x10x1
14	0301 2318 00	4	Screw	M5x16 12.9
	0902 0113 00	1	Allen key	5 mm. Accessory included
	4080 0182 14	1	Mandrel	Ø40.5/47 mm. Service tool for dismantling of Bushing. For further information, pls see Service instructions
		1	Plate	L=15mm, D=56mm. Service tool for assembling of Bushing. For further information, pls see Service instructions
	4080 0207 07	1	Support ring	Ø50/53 x 83 mm. Service tool for assembling of Bushing. For further information, pls see Service instructions

Impact mechanism

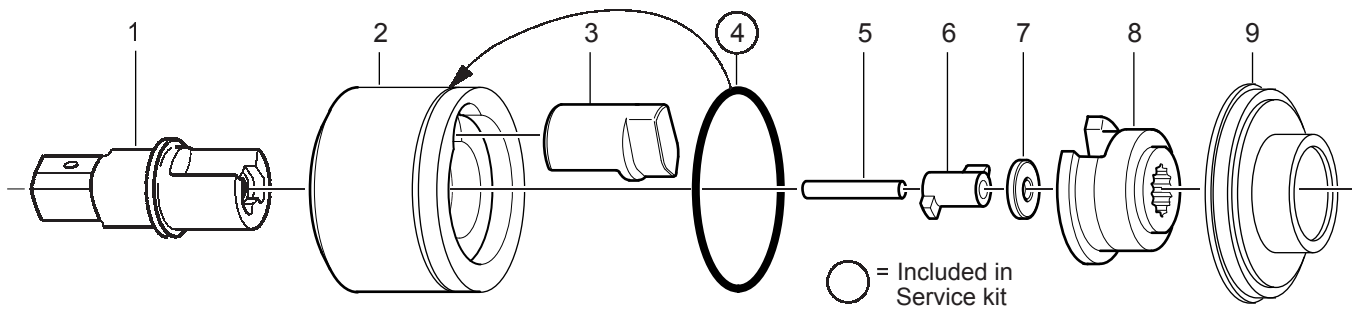

0001431

Ref. No.	Ordering No.	Qty	Description	Remark / Included in Service kit
1	4250 2472 00	1	Anvil	1" Square
2	4250 2515 00	1	Hammer	
3	4250 2511 00	1	Clutch jaw	
4	-	1	O-ring	82.14x3.53 / Service kit 4081 0442 90
5	4250 2514 00	1	Pin	
6	4250 2512 00	1	Cam	
7	4250 2513 00	1	Washer	
8	4250 2476 01	1	Driver	
9	4250 2516 01	1	Cover	

Motor and motorcasing

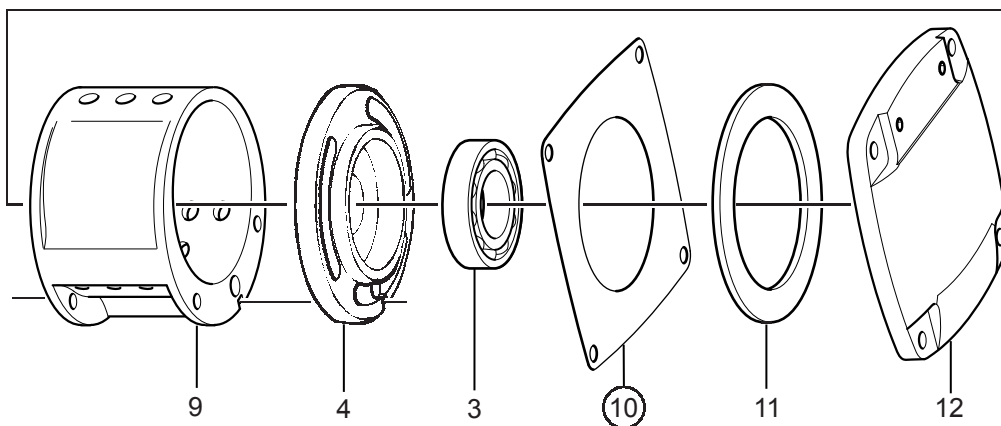
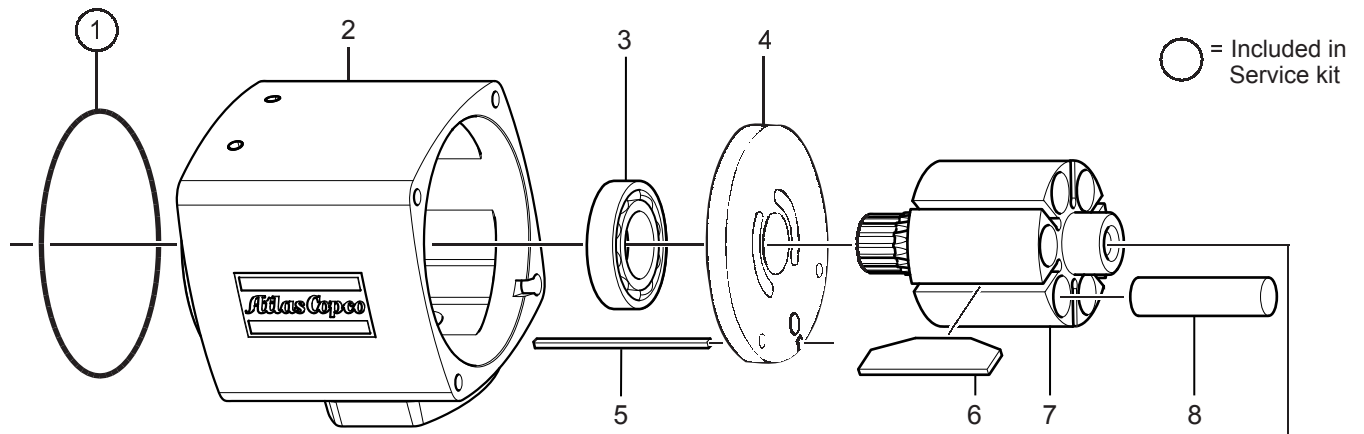

0000280

Ref. No.	Ordering No.	Qty	Description	Remark / Included in Service kit
1	-	1	O-ring	95x2 / Service kit 4081 0442 90
2	4250 2842 00	1	Motor casing	
3	4250 0657 00	2	Ball bearing	SKF 98205
4	4250 2834 00	2	End plate	
5	4250 2857 00	1	Key	3x82

Ref. No.	Ordering No.	Qty	Description	Remark / Included in Service kit
6	4250 2506 90	1	Vane kit	6 pcs
7	4250 2475 00	1	Rotor	
8	4250 2507 90	1	Plug kit	6 pcs
9	4250 2840 00	1	Cylinder	
10	-	1	Gasket	Service kit 4081 0442 90
11	4250 2833 00	1	Washer	
12	4250 2478 00	1	Cover	
	4080 1331 81	1	Motor service tool	Accessory included. Service tool for dismantling/ assembling of Motor. For further information, pls see Service instructions
	4080 0206 05	1	Mandrel	Ø108/125 mm. Service tool for dismantling/ assembling of Motor. For further information, pls see Service instructions
	4080 1332 00	1	Mandrel	Ø79 x 45 mm. Service tool for dismantling/ assembling of Motor bearings. For further information, pls see Service instructions

Handle

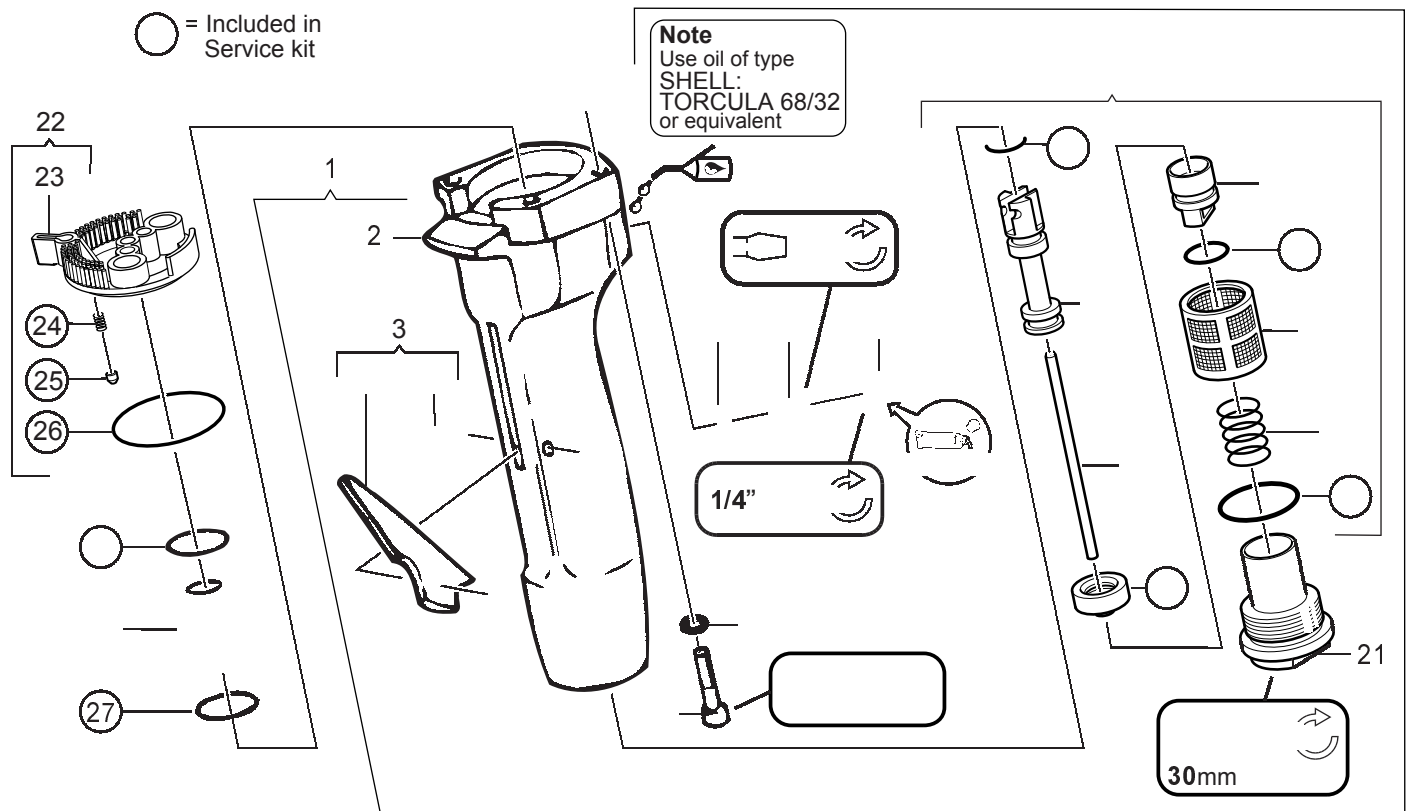

Ref. No.	Ordering No.	Qty	Description	Remark / Included in Service kit
1(2-21)	4250 0931 92	1	Handle, compl.	
2	-	1	Handle	
3(4-5)	4250 0807 90	1	Trigger, compl.	
4	-	1	Trigger	
5	-	1	Pin	4x22 / Small parts kit 4082 0051 90
6	-	1	O-ring	4.1x1.6 / Small parts kit 4082 0051 90
7	4150 0188 00	1	Screw	
8	-	1	Plug	Small parts kit 4082 0051 90
9	-	4	Washer	5.3x10x1.5 / Small parts kit 4082 0051 90
10	-	4	Screw	M5x40 12.9 / Small parts kit 4082 0051 90
11(12-20)	4250 0726 91	1	Valve, compl.	
12	-	1	O-ring	11.3x2.4 / Service kit 4081 0442 90
13	-	1	Guide	
14	4250 0732 00	1	Pin	
15	4250 0730 00	1	Valve seat	Service kit 4081 0442 90
16	-	1	Valve	
17	-	1	O-ring	17.1x1.6 / Service kit 4081 0442 90
18	4250 0729 00	1	Strainer	
19	4250 0725 00	1	Spring	
20	-	1	O-ring	29.2x3 / Service kit 4081 0442 90

Ref. No.	Ordering No.	Qty	Description	Remark / Included in Service kit
21	4250 0724 02	1	Adapter	G1/2". With NPT-thread (for the US, Canada) 4250 0724 03
22(23-26)	4250 0878 92	1	Reversing valve, compl.	
23	-	1	Reversing valve	
24	-	1	Spring	Service kit 4081 0442 90
25	-	1	Retainer pin	Service kit 4081 0442 90
26	-	1	O-ring	49.5x3 / Service kit 4081 0442 90
27	-	2	O-ring	19.2x3 / Service kit 4081 0442 90
28	4250 0735 00	1	Sleeve	
	0902 0112 00	1	Allen key	4 mm. Accessory included
	0902 0165 00	1	Allen key	1/4". Accessory included

Service Kits

Service kit — Clutch housing / Impact mechanism / Motor and motorcasing / Handle

Ordering No. 4081 0442 90

Ordering No.	Qty	Description	Remark / Included in Service kit
-	1	O-ring	42x2.5
-	1	O-ring	82.14x3.53
-	1	O-ring	95x2
-	1	Gasket	
-	1	O-ring	11.3x2.4
4250 0730 00	1	Valve seat	
-	1	O-ring	17.1x1.6
-	1	O-ring	29.2x3
-	1	Spring	
-	1	Retainer pin	
-	1	O-ring	49.5x3
-	2	O-ring	19.2x3

Service kits are designed for a variety of products. This Service kit may contain more parts than listed in the table and parts might remain unused.

Small-parts kit — Clutch housing / Handle

Ordering No. 4082 0051 90

Ordering No.	Qty	Description	Remark / Included in Service kit
-	1	Shim	45x55x0.2
0300 0276 79	2	Washer	6.4x12.3x3
-	1	Pin	4x22
-	1	O-ring	4.1x1.6
-	1	Plug	
-	4	Washer	5.3x10x1.5
-	4	Screw	M5x40 12.9

Service kits are designed for a variety of products. This Service kit may contain more parts than listed in the table and parts might remain unused.

Service Tools

Service Tools

Section	Ordering No.	Description	Remark
Bushing	4080 0182 14	Mandrel	L=120mm, D=47mm
Bushing	-	Plate	L=15mm, D=56mm
Motor	4080 0206 05	Mandrel	
Motor	4080 1331 81	Motor service tool	4pcs
Motor and motorcasing	4080 1331 81	Motor service tool	Accessory included. Service tool for dismantling/ assembling of Motor. For further information, pls see Service instructions
Motor and motorcasing	4080 0206 05	Mandrel	Ø108/125 mm Service tool for dismantling/ assembling of Motor. For further information, pls see Service instructions

Section	Ordering No.	Description	Remark
Motor and mo- torcasing	4080 1332 00	Mandrel	Ø79 x 45 mmService tool for dismantling/ assembling of Motor bearings. For further information, pls see Service instructions
Assembly/ dis- assembly tool	4080 1331 81	Assembly/ disassembly tool	For assembly and disassembly of motor into casing, see service instruction

Accessories included

Allen key (1/4")



Ref. No.	Ordering No.	Qty	Description	Remark / Included in Service kit
	0902 0165 00	1	Allen key	1/4"

Assembly/ disassembly tool



Ref. No.	Ordering No.	Qty	Description	Remark / Included in Service kit
	4080 1331 81		Assembly/ disassembly tool	For assembly and disassembly of motor into casing, see service instruction

Cup



Ref. No.	Ordering No.	Qty	Description	Remark / Included in Service kit
	4080 1358 00		Cup	For filling Impact mechanism with grease, see service instruction



© Copyright 2012, Atlas Copco Industrial Technique AB. All rights reserved. Any unauthorized use or copying of the contents or part thereof is prohibited. This applies in particular to trademarks, model denominations, part numbers and drawings. Use only authorized parts. Any damage or malfunction caused by the use of unauthorized parts is not covered by Warranty or Product Liability.

Out of respect to wildlife and nature, our technical literature is printed on environmentally friendly paper.