

LMS18 HR10



Printed Matter No. 9836 6509 00

Impact Wrench

Valid from Serial No. A2520001
2012-12

Product Instructions



	 WARNING



General information

⚠ WARNING

- Read all safety warnings and all instructions.
Failure to follow the warnings and instructions may result in electric shock, fire and/or serious injury.
- Save all warnings and instructions for future reference.

Safety signal words

The safety signal words Danger, Warning, Caution, and Notice have the following meanings:

DANGER	DANGER indicates a hazardous situation which, if not avoided, will result in death or serious injury.
WARNING	WARNING indicates a hazardous situation which, if not avoided, could result in death or serious injury.
CAUTION	CAUTION, used with the safety alert symbol, indicates a hazardous situation which, if not avoided, could result in minor or moderate injury.
NOTICE	NOTICE is used to address practices not related to personal injury.

Warranty

Contact the Atlas Copco sales representative within your area to claim a product. Warranty will only be approved if the product has been installed, operated and overhauled according to the Operating Instructions.

Please also see the delivery conditions applied by the local Atlas Copco company.

ServAid

ServAid is a utility for providing updated product information concerning:

- Safety instructions
- Installation, Operation and Service instructions
- Exploded views

ServAid facilitates the ordering process of spare parts, service tools and accessories for the product of your choice. It is continuously updated with information of new and redesigned products.

You can use ServAid to present content in a specific language, provided translations are available, and to display information about obsolete products. ServAid offers an advanced search functionality of our entire product range.

ServAid is available on DVD and on the web:

<http://servaidweb.atlascopco.com>

For further information contact your Atlas Copco sales representative or e-mail us at:

servaid.support@se.atlascopco.com

Further information

For further information concerning this product, please see Printed Matter No. -, available in ServAid on the web.

Overview

Applications

This powerful, high-speed impact wrench (LMS) is typically used for loosening applications where fast tightening or disassembly is needed.

Service intervals

Service recommendations

Overhaul and preventive maintenance is recommended at regular intervals. If the machine is not working properly, it should immediately be taken out of operation for inspection. At the overhauls, all parts should be cleaned accurately and defective or worn parts should be replaced.

Installation requirement

General

The machine is designed for a working pressure (e) of 6.3 - 7 bar (max.) = 630 - 700 kPa (90 - 102 psi).

If the compressed air line pressure is higher than 7 bar it is preferable reduced with a pressure regulator of the type Atlas Copco REG.

The Atlas Copco Air Line Test equipment is suitable for checking of air pressure and airflow at the installation point (please see AirLine Accessories in our main catalogue).

The machine can operate at a lower working pressure. Maximum torque will be reduced at lower pressures.

- ⓘ **If frequent used for tightening or loosening that need longer time than 3-5 seconds, a larger wrench should be used. Otherwise the servicelife of the impact mechanism will be reduced.**

To avoid pressure drop use recommended hosesize, length, and connections. For more information please read Atlas Copco Airline Installations, Ordering No. 9833 1191 01.

Air quality

- For optimum performance and maximum machine life we recommend the use of compressed air with a maximum dew point of +10°C. We also recommend the installation of an Atlas Copco refrigeration-type air dryer.
- Use a separate air filter of type Atlas Copco FIL. This filter removes solid particles larger than 15 microns and also removes more than 90 % of liquid water. The filter must be installed as close as possible to the machine/equipment and prior to any other air preparation unit such as REG or DIM (please see Air Line Accessories in our main catalogue). Blow out the hose before connecting.

Models which need air lubrication:

- The compressed air must contain a small quantity of oil.
We strongly recommend that you install an Atlas Copco oil-fog lubricator (DIM). This should be set according to air consumption by the air line tool according to the following formula:

$L = \text{Air consumption (litre/s)}$

(May be found in our sales literature).

$D = \text{Number of drops per min (1 drop} = 15 \text{ mm}^3)$

$L * 0.2 = D$

this applies to the use of long work cycle air line tools. A single point lubricator type Atlas Copco Dosol can also be used for tools with short running cycles.

Information about Dosol settings may be found under Air Line Accessories in our main catalogue.

Lubrication-free models:

- In the case of lubrication-free tools it is up to the customer to decide on the peripheral equipment to be used. However, it is no disadvantage if the compressed air contains a small quantity of oil e.g. supplied from a fog lubricator (DIM) or Dosol system. This does not apply to turbine tools, which should be kept oil free.

Installation proposal

Choosing the correct couplings, hose and clamps can be a troublesome digging into details. To save your time and to ensure correct capacity of the airline installation, from the tapping point to the tool, we offer you an installation proposal.

 BALL VALVE + MIDI F/RD 15 + ERGOQIC 10
8202 0829 11

ErgoNIP 10 5 m PVC 10 ErgoQIC 08
+Ergo NIP 08 M08
8202 1180 30

ErgoNIP 08 0.7 m PVC 10 Nipple
Male 3/8" BSPT
8202 1180 50

Ergonomics

Ergonomic guidelines

- 1) Take frequent breaks and change work positions frequently.
- 2) Adapt the workstation area to your needs and the work task.
 - Adjust for convenient reach range by determining where parts or tools should be located to avoid static load.
 - Use workstation equipment such as tables and chairs appropriate for the work task.
- 3) Avoid work positions above shoulder level or with static holding during assembly operations.
 - When working above shoulder level, reduce the load on the static muscles by reducing the weight of the tool, using for example torque arms, hose reels or weight balancers. You can also reduce the load on the static muscles by holding the tool close to the body.
 - Make sure to take frequent breaks.
 - Avoid extreme arm or wrist postures, particularly for operations requiring a degree of force.
- 4) Adjust for convenient field of vision by minimizing movement of the eyes and head during the work task.
- 5) Use the appropriate lighting for the work task.
- 6) Select the appropriate tool for the work task.
- 7) Use ear protection equipment in noisy environments.
- 8) Use high-quality inserted tools or consumables to minimize exposure to excessive levels of vibrations.
- 9) Minimize exposure to reaction forces.
 - When cutting:
A cut-off wheel can get stuck if the wheel is either bent or if it is not guided properly. Make sure to use correct flanges for cut-off wheels and avoid bending the wheel during cut-off operation.
 - When drilling:
The drill might stall when the drill bit breaks through. Make sure you use support handles if the stall torque is too high. The safety standard ISO11148 part 3 recommends to use something to absorb the reaction torque above 10 Nm for pistol grip tools and 4 Nm for straight tools.
 - When using direct driven screw or nutrunners:
Reaction forces depend on tool setting and joint characteristics. The ability to bear reaction forces depends on the operator's strength and posture. Adapt the torque setting to the operator's strength and posture and use a torque arm or reaction bar if the torque is too high.
- 10) Use dust extraction system or mouth protection mask in dusty environments.

Operating instructions

Tightening torque

The tightening torque attained depends on the air pressure, tightening time and bolted joint in question. Extension pieces and worn sockets will reduce the effective tightening torque. Oversized power sockets (diameter and or length) will overload the impact mechanism and reduce the life of vital parts as the impact mechanism. The impact wrench must be used within the specified torque range. **Never exceed the recommended maximum tightening torque.**

Test methods

Measurement using a hydraulic Torque Tension tester is recommended for testing tool performance, see Test data.

Maintenance

Service instructions

Overhaul and preventive maintenance are recommended at regular intervals once a year or after max. 100 000 tightening operations at the latest, whichever comes first. More frequent overhauls may be required if the machine is used for heavy-duty applications. If the machine fails to function correctly, it must be decommissioned immediately for inspection.

The strainer at the air inlet must be cleaned regularly in order to prevent clogging due to contamination. The machine capacity will otherwise be reduced.

All parts must be cleaned thoroughly during overhaul work and defective or worn parts must be replaced

It is important to ensure that the threaded connections on the machine are tightened properly; i.e. in accordance with the specifications in the exploded views. Lubricate the threads with grease prior to fitting.

ⓘ All O-rings must be greased prior to assembly.

When the machine is in constant operation, installation of an Atlas Copco DIM oil mist lubricating device or a Dosol type single point lubricating device is recommended.

Impact mechanism

Check the specified wear limits and replace all parts which exceed these. See Inspection.

ⓘ Recommended maximum wear limits for the clutch jaw, anvil and driver.

Rust protection and internal cleaning

Water in the compressed air, dust and wear particles cause rust and sticking of vanes, valves etc. An air filter should be installed close to the machine (see 'Air quality'). Before longer standstills, flush with oil (some drops) into the air inlet, run the machine for 5-10 seconds when absorbing the oil in a cloth.

How to optimize service and performance of your impact wrench

The service life of the impact mechanism is mainly dependent on:

- service intervals
- air pressure
- tightening time/torque
- number of tightening
- socket/bolt size
- socket length

Service intervals

Shorter service intervals with cleaning and lubrication of the impact parts will improve the function and reduce the wear. Follow our service recommendations.

Air pressure, tightening time/torque and number of tightening

It is obvious that wear will increase with increased air pressure, longer tightening time/higher torque and number of tightening.

A tightening time of 1-5 seconds is recommended. The Skidmore-Wilhelm table in Test data can be used as a guide for max. tightening time.

Longer tightening or loosening times will increase wear, producing malfunction and risk of breakage.

Socket and bolt size

Each impact wrench covers a certain bolt size range. The impact mechanism parts have been designed for good durability in combination with the recommended standard socket/bolt size.

Usage of oversized sockets/bolts will increase premature wear and risk of breakage.

If frequent square drive breakages occur and different square drive sizes are available, use the largest size.

Long sockets/extensions

It is better to use extensions + standard socket instead of long or extra long sockets as the lower inertia /mass of the extension will give less stress on the impact mechanism. However an extension will reduce the applied torque to some degree.

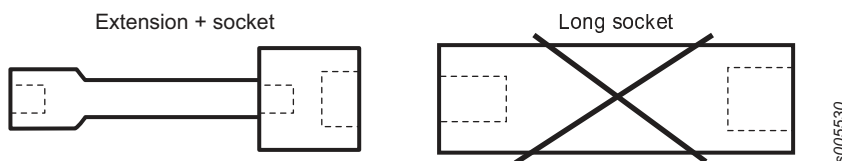

Recommendations for maximum socket / bolt size

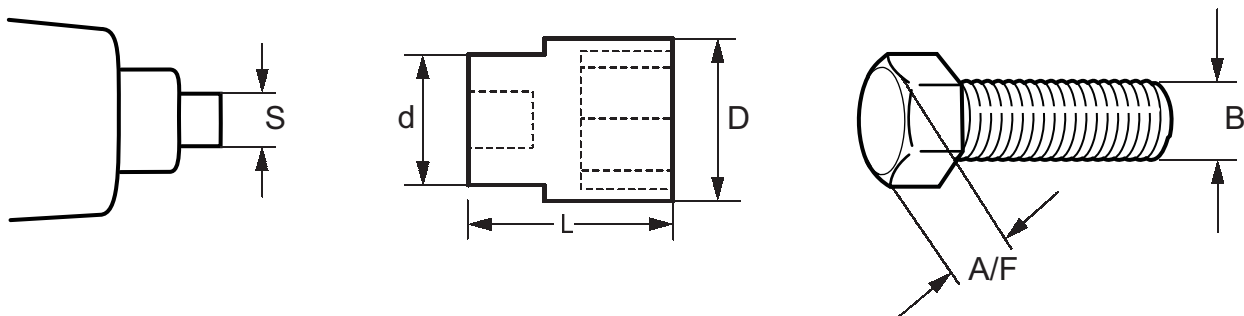

Drive S	Socket size d (max)	Socket length L (max)	Socket size D (max)	Socket opening A/F (max)	Bolt size B (max)
3/8"	22mm	34mm	25mm	17mm (11/16")	M10 (7/16")

Dismantling/ Assembling

Symbols

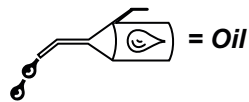
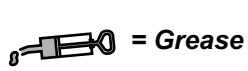

s011130

Bushing

Dismantling

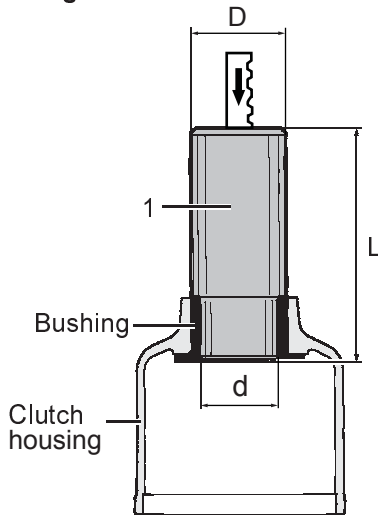

Assembling

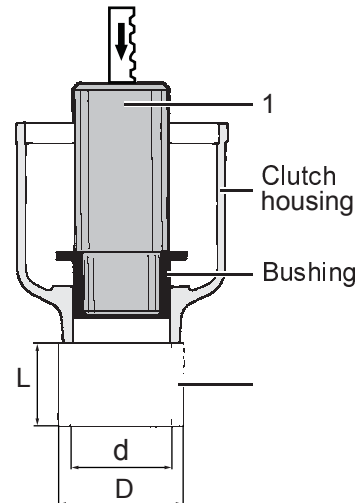

s000195

Ref. No.	Ordering No.	Qty	Description	Remark / Included in Service kit
1	4080 0517 00	1	Mandrel	L=100mm, D=23mm, d=17.5mm
2	-	1	Support ring	L=30mm, D=27mm, d=24mm

End plate and cylinder

Dismantling

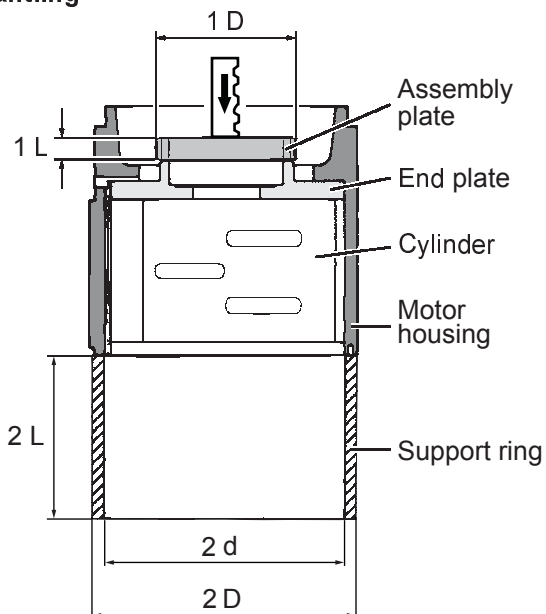

Assembling

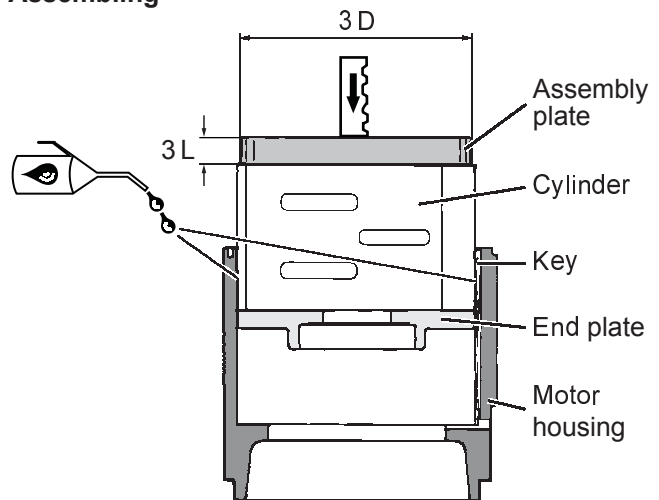

s011113

Ref. No.	Ordering No.	Qty	Description	Remark / Included in Service kit
1	-	1	Plate	L=10mm, D=36mm
2	4080 0207 08	1	Support ring	L=75mm, D=47mm, d=45mm
3	4080 0208 01	1	Plate	L=15mm, D=47mm

Motor bearings

Dismantling

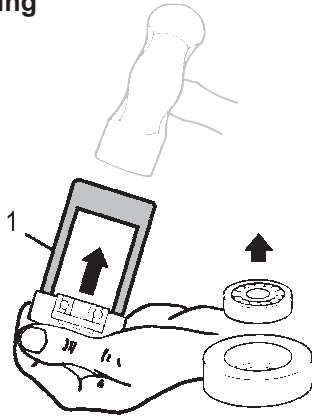

Assembling

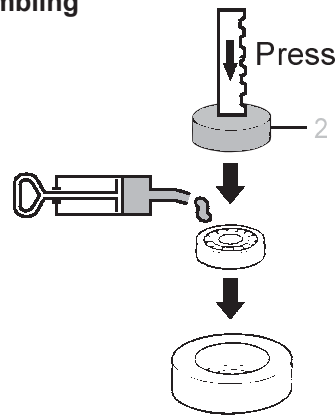

Ref. No.	Ordering No.	Qty	Description	Remark / Included in Service kit
1	4080 0182 13	1	Mandrel	
2	-	1	Plate	L=10mm, D=35mm

Inspection

Inspection for wear on impact parts

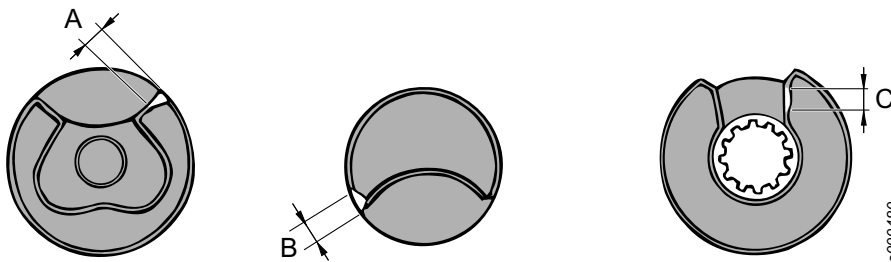

Wear limits

Anvil A (max)	Clutch jaw B (max)	Driver C (max)
1.3 mm	1.3 mm	1.8 mm

Inspection of silencer

Change or clean the filters regularly. Clogged filters will reduce power output.

Inspection of motor parts

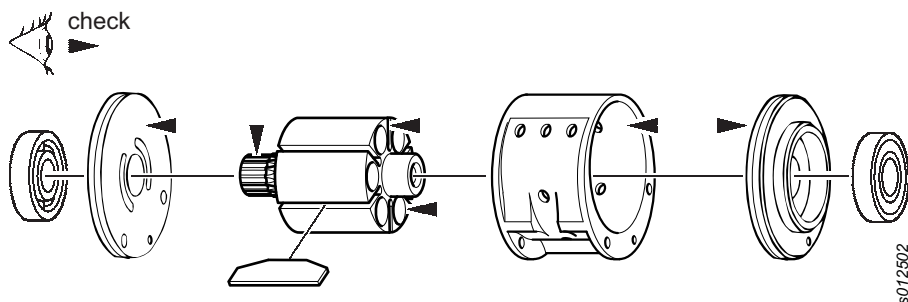

- **Clean all parts** before inspection.
- **End plates:** Check that they not are scored or scratched. If these are shallow, polish with fine grinding paste against a face plate. Clean thoroughly.
- **Rotor:** Check that the end faces do not have any marks or burrs. Check that the splines are not worn or cracked. Check that there are no cracks at the holes for the plugs.
- **Cylinder:** Check that the bore is not scored or scratched. If these are shallow, polish with a fine grinding cloth. Clean thoroughly.

Lubrication

Lubrication guide

Brand	General purpose grease	Impact mechanism	Air and motor lubrication
BP	Energrease LS-EP2		Energol E46
Castrol	Spheerol EP L2		
Esso	Beacon EP2		Arox EP46
Q8	Rembrandt EP2		Chopin 46
Mobil	Mobilegrease XHP 222		Almo oil 525
Shell	Alvania EP2	Alvania Grease RL 2	Torcula 32
Texaco	Multifak EP2		Aries 32
Molycote			

Lubrication of impact mechanism

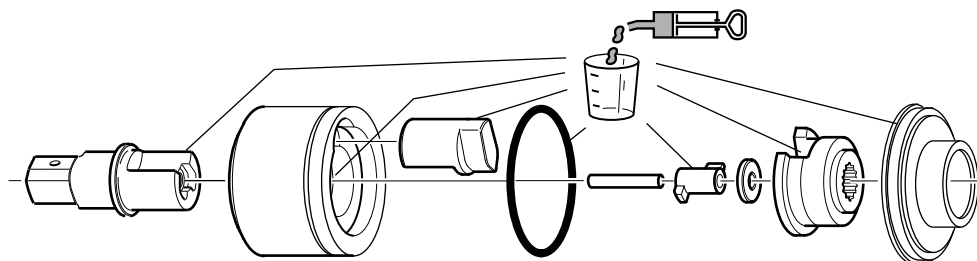

Lubrication of motor parts

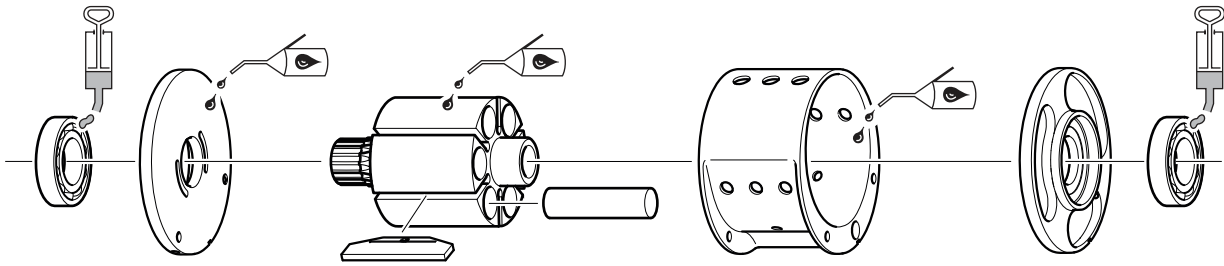

s001000

Note

- No grease is needed for protected Ball bearings (ex. 2Z).
- Where oil is needed, apply only a thin layer.

Test data

Test on Tension tester (Skidmore-Wilhelm)

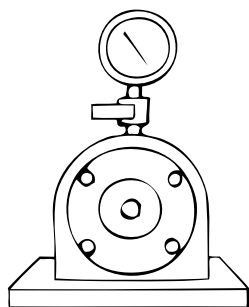

s005371

Test performance:

Test equipment according to the tables below.

Assemble selected test bolt set in the tester ensuring that threads and pressure faces are well lubricated with Molycote Longterm W2 or similar molybdenum disulphide lubricant.

Make 3 tightenings and check that the minimum tension can be reached.

Test conditions:

Air pressure = 6.3 bar (90 psi) dynamic.

Test result

Model	Tester	Bolt size	Min. Tension	Tightening time	Min. * Free speed	Test hose (3 m) inner diam.
LMS08 HR10	Skidmore-Wilhelm model J	5/8"	34 kN	2 s	11000 rpm	6.3 mm (1/4")
LMS08 HR42	Skidmore-Wilhelm model J	5/8"	21 kN	2 s	11000 rpm	6.3 mm (1/4")
LMS08 SR10	Skidmore-Wilhelm model J	5/8"	33 kN	2 s	11000 rpm	6.3 mm (1/4")
LMS08 SR42	Skidmore-Wilhelm model J	5/8"	19 kN	2 s	11000 rpm	6.3 mm (1/4")
LMS18 HR10	Skidmore-Wilhelm model J	7/8"	39 kN	2 s	7000 rpm	10 mm (3/8")
LMS18 HR13	Skidmore-Wilhelm model J	7/8"	53 kN	2 s	7000 rpm	10 mm (3/8")
LMS28 HR13	Skidmore-Wilhelm model RL	3/4"	83 kN	2 s	8000 rpm	10 mm (3/8")
LMS38 HR13	Skidmore-Wilhelm model RL	1"	110 kN	2 s	6800 rpm	10 mm (3/8")
LMS48 HR20	Skidmore-Wilhelm model RL	1"	161 kN	3 s	5500 rpm	12.5 mm (1/2")
LMS58 HR20	Skidmore-Wilhelm model H	1 1/4"	260 kN	3 s	4700 rpm	12.5 mm (1/2")
LMS58 HR25	Skidmore-Wilhelm model H	1 1/4"	270 kN	3 s	4700 rpm	12.5 mm (1/2")
LMS68	Skidmore-Wilhelm model H	1 1/2"	470 kN	4 s	4200 rpm	16 mm (5/8")
LMS88	Skidmore-Wilhelm model K	2"	660 kN	6 s	3200 rpm	16 mm (5/8")

* = If Free speed is to low: check silencer for clogged filters.

Exploded views/tables

Spare parts

Parts without ordering number are not delivered separately for technical reasons.

The use of other than genuine Atlas Copco replacement parts may result in decreased tool performance and increased maintenance and may, at the company option, invalidate all warranties.

Clutch housing

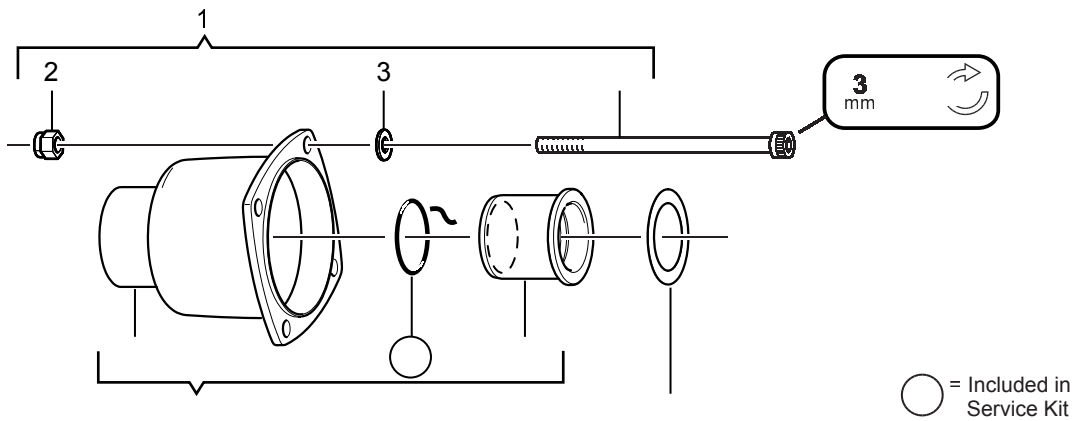

Ref. No.	Ordering No.	Qty	Description	Remark / Included in Service kit
1(2-4)	4250 2942 90	1	Screw, kit	
2	-	4	Lock nut	M4x6
3	-	4	Washer	4.3x8x0.8
4	-	4	Screw	MC6S M4x86 12.9
5(6-8)	4250 2779 90	1	Clutch housing, compl.	
6	-	1	Clutch housing	
7	-	1	O-ring	18.1x1.6 / Service kit 4081 0466 90
8	4250 2932 00	1	Bushing	
9	-	1	Shim	18x25x0.3 / Service kit 4081 0466 90
	4080 0517 00	1	Mandrel	L=100mm, D=23mm, d=17.5mm. Service tool for dismantling/ assembling of Bushing. For further information, pls see Service instructions
	-	1	Support ring	L=30mm, D=27mm, d=24mm. Service tool for dismantling/ assembling of Bushing. For further information, pls see Service instructions
	0902 0111 00	1	Allen key	3 mm. Accessory included. Service tool.

Impact mechanism

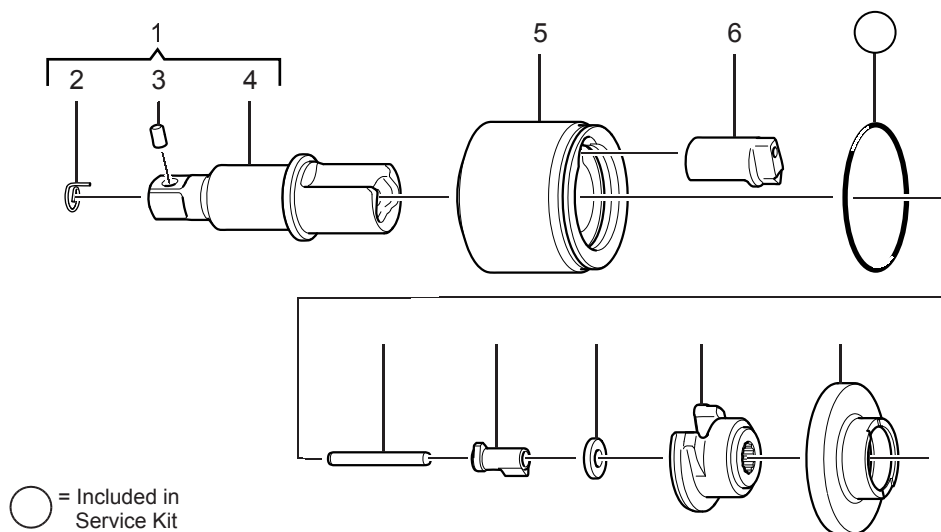

Ref. No.	Ordering No.	Qty	Description	Remark / Included in Service kit
1(2-4)	4250 2856 81	1	Anvil, compl.	
2	4250 1949 00	1	Spring	
3	4250 1948 00	1	Retainer pin	
4	-	1	Anvil	3/8" Square
5	4250 2839 00	1	Hammer	
6	4250 2934 00	1	Clutch jaw	
7	0663 6133 00	1	O-ring	37.1x1.6 / Service kit 4081 0466 90
8	4250 1140 01	1	Pin	
9	4250 1141 00	1	Cam	
10	4250 1139 00	1	Washer	
11	4250 2939 00	1	Driver	
12	4250 2700 00	1	Cover	

Motor

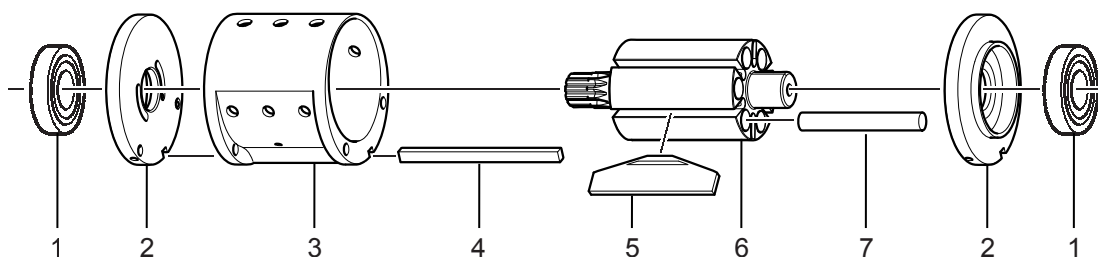

0001230

Ref. No.	Ordering No.	Qty	Description	Remark / Included in Service kit
1	0502 1265 00	2	Ball bearing	6000-2Z
2	4250 2938 00	2	End plate	
3	4250 2937 00	1	Cylinder	
4	4250 2935 00	1	Key	
5	4250 1749 91	1	Vane, kit	6 pcs
6	4250 2838 00	1	Rotor	
7	4250 2941 90	1	Plug, kit	6 pcs
-	-	1	Plate	Service tool for Motor. For further information, pls see Service instructions
-	4080 0207 08	1	Support ring	Service tool for Motor. For further information, pls see Service instructions
-	4080 0208 01	1	Plate	Service tool for Motor. For further information, pls see Service instructions
-	4080 0182 13	1	Mandrel	Ø35.5/40 mm. For dismantling of Motor bearings. For further information, pls see Service instructions
-	-	1	Plate	For assembling of Motor bearings. For further information, pls see Service instructions

Motor housing

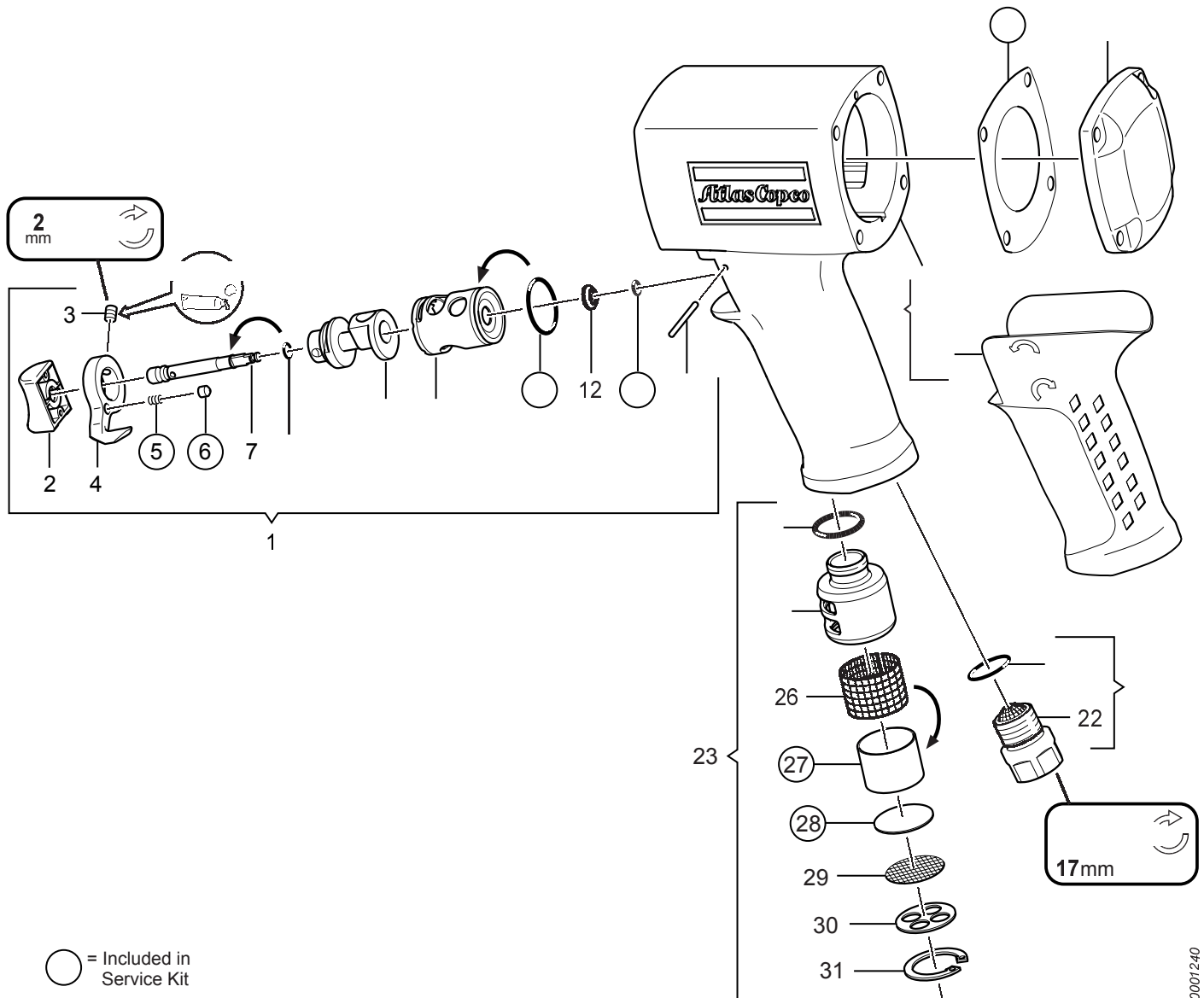

○ = Included in Service Kit

0001240

Ref. No.	Ordering No.	Qty	Description	Remark / Included in Service kit
1(2-14)	4250 1933 80	1	Reversing valve, compl.	
2	4250 1660 00	1	Push button	
3	-	1	Stop screw	M4x5 / Service kit 4081 0466 90
4	4250 1658 00	1	Reversing knob	
5	-	1	Spring	Service kit 4081 0466 90
6	-	1	Retainer pin	Service kit 4081 0466 90
7	4210 3622 00	1	Valve pin	
8	-	1	O-ring	4x1
9	4250 1934 00	1	Reversing valve	
10	4250 1933 00	1	Liner	
11	-	1	O-ring	16.1x1.6 / Service kit 4081 0466 90
12	4250 1935 03	1	Washer	
13	-	1	O-ring	1.42x1.52 / Service kit 4081 0466 90
14	-	1	Needle bearing	2x21.8 / Service kit 4081 0466 90
15(16-17)	4250 2878 00	1	Motor housing, compl.	
16	4250 1939 93	1	Rubber cover	
17	-	1	Motor housing	
18	-	1	Gasket	Service kit 4081 0466 90
19	4250 2798 00	1	Cover	
20(21-22)	4250 1663 90	1	Adapter, compl.	G1/4". With NPT-thread (for the US, Canada) 4250 1663 91
21	-	1	O-ring	15.1x1.6 / Service kit 4081 0466 90
22	-	1	Adapter	
23(24-31)	4250 2795 80	1	Silencer, compl.	
24	-	1	O-ring	12.37x2.62 / Service kit 4081 0466 90

Ref. No.	Ordering No.	Qty	Description	Remark / Included in Service kit
25	-	1	Silencer	
26	-	1	Net	
27	-	1	Filter	Service kit 4081 0466 90
28	-	1	Filter	Service kit 4081 0466 90
29	-	1	Net	
30	-	1	Cover	
31	-	1	Circlip	SGH 23 / Service kit 4081 0466 90

Service Kits

Service kit — Clutch housing / Impact mechanism / Motor housing

Ordering No. 4081 0466 90

Ordering No.	Qty	Description	Remark / Included in Service kit
-	1	O-ring	18.1x1.6
-	1	Shim	18x25x0.3
0663 6133 00	1	O-ring	37.1x1.6
-	1	Stop screw	M4x5
-	1	Spring	
-	1	Retainer pin	
-	1	O-ring	16.1x1.6
-	1	O-ring	1.42x1.52
-	1	Needle bearing	2x21.8
-	1	Gasket	
-	1	O-ring	15.1x1.6
-	1	O-ring	12.37x2.62
-	1	Filter	
-	1	Filter	
-	1	Circlip	SGH 23

Service kits are designed for a variety of products. This Service kit may contain more parts than listed in the table and parts might remain unused.

Service Tools

Service Tools

For motor

Section	Ordering No.	Description	Remark
Bushing	4080 0517 00	Mandrel	L=100mm, D=23mm, d=17.5mm
Bushing	-	Support ring	L=30mm, D=27mm, d=24mm
End plate and cylinder	-	Plate	L=10mm, D=36mm
End plate and cylinder	4080 0207 08	Support ring	L=75mm, D=47mm, d=45mm
End plate and cylinder	4080 0208 01	Plate	L=15mm, D=47mm
Motor bearings	bear- 4080 0182 13	Mandrel	
Motor bearings	bear- -	Plate	L=10mm, D=35mm
Emmanchement	4080 0517 00	Mandrel	L=100mm, D=23mm, d=17.5mm
Emmanchement	-	Support ring	L=30mm, D=27mm, d=24mm
Plaques d'ex-trémité et cylindre	-	Plate	L=10mm, D=36mm
Plaques d'ex-trémité et cylindre	4080 0207 08	Support ring	L=75mm, D=47mm, d=45mm
Plaques d'ex-trémité et cylindre	4080 0208 01	Plate	L=15mm, D=47mm

Section	Ordering No.	Description	Remark
Roulements à billes	4080 0182 13	Mandrel	
Roulements à billes	-	Plate	L=10mm, D=35mm
Clutch housing	4080 0517 00	Mandrel	L=100mm, D=23mm, d=17.5mm Service tool for dismantling/ assembling of Bushing. For further information, pls see Service instructions
Clutch housing	0902 0111 00	Allen key	3 mm Accessory included. Service tool.
Motor	-	Plate	Service tool for Motor. For further information, pls see Service instructions
Motor	4080 0207 08	Support ring	Service tool for Motor. For further information, pls see Service instructions
Motor	4080 0208 01	Plate	Service tool for Motor. For further information, pls see Service instructions

Accessories included

Cup



Ref. No.	Ordering No.	Qty	Description	Remark / Included in Service kit
	4080 1358 00		Cup	For filling Impact mechanism with grease, see service instruction

Productivity kit FRL stand

Ref. No.	Ordering No.	Qty	Description	Remark / Included in Service kit
1	9090 3030 01	1	Productivity kit FRL stand	NPT (Hose included, tool nipple not included)

Productivity kit FRL stand

Ref. No.	Ordering No.	Qty	Description	Remark / Included in Service kit
1	9090 3030 02	1	Productivity kit FRL stand	BSP (Hose included, tool nipple not included)

Suspension yoke

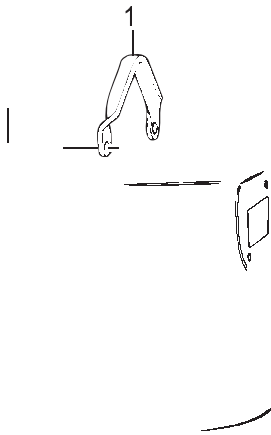

Ref. No.	Ordering No.	Qty	Description	Remark / Included in Service kit
1	4250 0872 00	1	Suspension yoke	Can be adjusted to fit different hole patterns.

