

sez. A-A

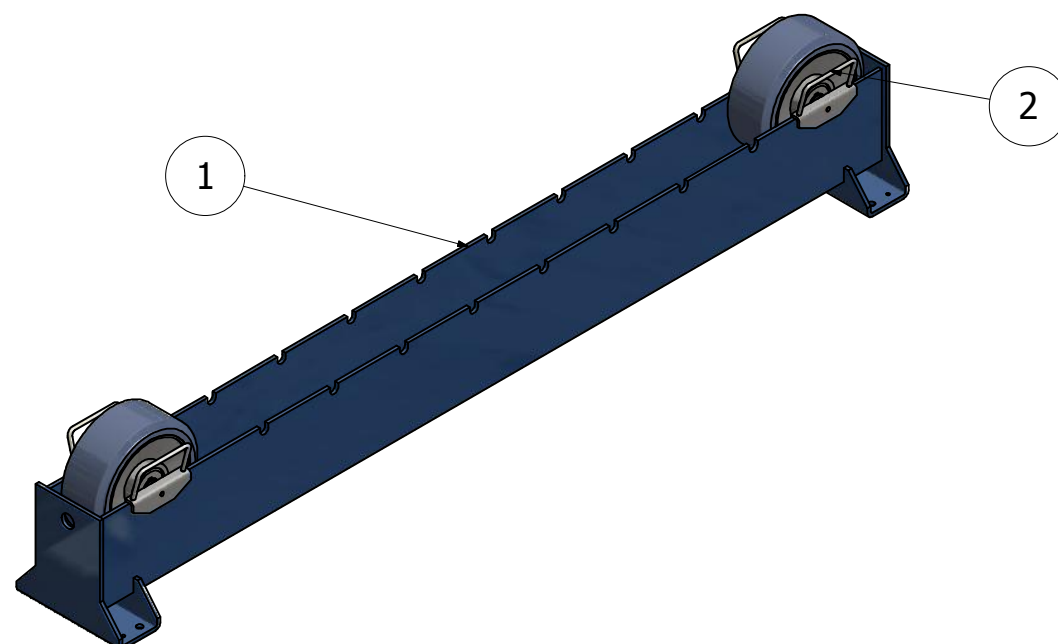
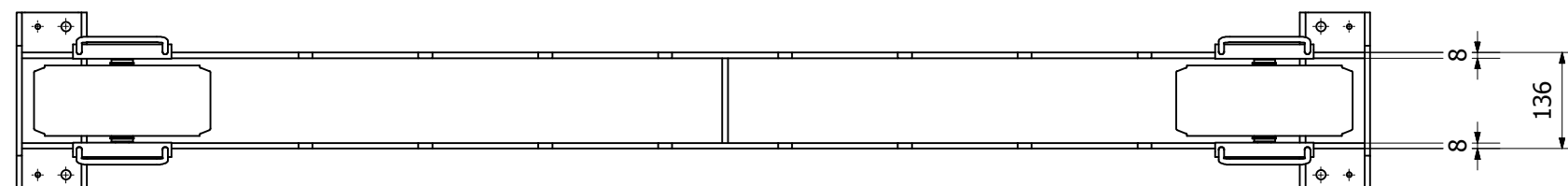
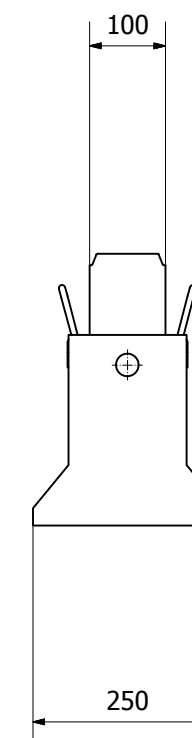
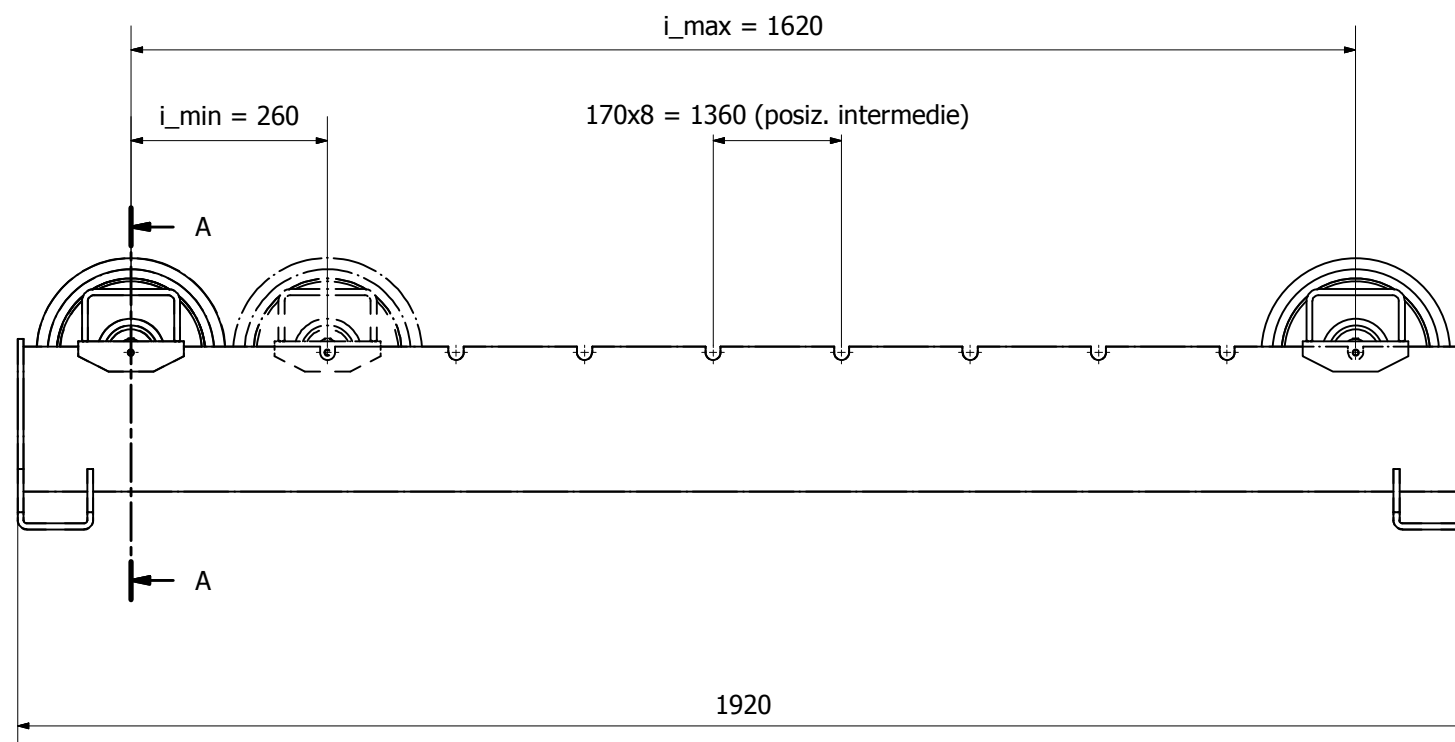

2	assieme ruota folle	2	10 kg	P1902000
1	struttura folle lavorata	1	56 kg	P1901002
Pos.	Denominazione	n° pezzi	Peso	Rif. Disegno
Data: 15/01/2013	Materiale:	Peso: 75 kg	Dis: M.Golin	PR 20
Denominazione: PR20 folle				Scala: 1:10
SARTORE SRL welding positioners			Dis. n°: P1900101	A3